

Micro Motion® Series 1000 and Series 2000 Transmitters with MVD™ Technology

Micro Motion® Series 1000 and Series 2000 transmitters with MVD™ technology deliver powerful features that make managing your process easier.

Advanced architecture with flexible installation options

- Integral or remote mounting provides maximum flexibility
- Cost-effective 4-wire interface reduces installation costs
- Remote field mount models available with stainless steel housing for harsher environments
- DIN rail option reduces complexity and increases versatility



Wide variety of I/O and application capabilities to fit your needs

- High-speed DSP for accuracy under the toughest conditions—entrained gas, high noise, high turndown, and more
- Concentration and net flow measurement eliminate the need for additional instruments
- Approved for custody transfer and certified for SIL2 and SIL3, which provides measurement confidence and reliability
- WirelessHART® option allows you to gain access to additional diagnostics and process information without added wiring costs

2200S	2400S	1700 2700	1500 2500	3300 3350	3500 3700	5700
Compact integral 2-wire transmitter	Compact integral transmitter	Versatile field-mount transmitter	Compact control-room transmitter	Frequency-input discrete controller	Integrated control and measurement platform	Advanced field-mount transmitter



Micro Motion Series 1000 and Series 2000 transmitters

The series 1000 and 2000 transmitters allow for the precise fit and integration for your Micro Motion Coriolis Flow and Density meters. Powerful adaptability to your installation needs combined with ultimate flexibility in output connections provides the proper fit for your application.

MVD technology makes your Micro Motion meter work smarter

- Front end signal processing gives faster response time and dramatically reduces signal noise
- Provides reduced wiring costs through use of standard 4 wire instrument cable
- On-board signal processing results in the cleanest, most accurate signal delivered, even with tough measurement conditions such as entrained gas

Smart Meter Verification: advanced diagnostics for your entire system

- A comprehensive test that can be run locally or from the control room to provide confidence in your meter functionality and performance
- Verifies that your meter performs as well as the day it was installed, giving you assurance in less than 90 seconds

Mounting and Installation flexibility to fit your exact needs

- Form factors include rugged field mounts with a full suite of hazardous area approvals or DIN rail packages for cost effective control room cabinets
- Local User Interfaces provide detailed operator feedback and accessibility
- Connection to new or existing Micro Motion sensors easily achieved through flexible configurations

Connection and Interface adaptability for seamless integration

- Broad combinations of analog and frequency outputs allow for you to get signals where you need them
- Digital outputs bring a wealth of information to your control room, with offerings for Smart WirelessHART, HART®, Modbus, FOUNDATION™ fieldbus and PROFIBUS-PA
- Direct plug and play operation with the Micro Motion Ethernet/IP Module for fast, efficient communications

Contents

Overview	3	Environmental limits	13
Applications	4	Environmental effects	13
Electrical connections	5	Hazardous area classifications	13
Output summary	5	Marine approval classifications	18
Input/output signal detail	7	Physical specifications	18
Digital communications	10	Dimensions	21
Power supply	12	Ordering Information	30

Overview

Feature	Model 2700	Model 2500	Model 1700	Model 1500
For applications requiring simultaneous monitoring of multiple flow variables <ul style="list-style-type: none"> ■ Selected combinations of outputs including milliamp, frequency, and discrete I/O ■ Modbus, HART, WirelessHART, FOUNDATION fieldbus, and PROFIBUS-PA digital communications ■ Simultaneously outputs multiple variables, including: mass flow rate, volume flow rate, gas standard volume flow rate, density, temperature, and drive gain 	•	•		
For applications requiring only mass flow or volume flow measurement <ul style="list-style-type: none"> ■ Milliamp and a frequency/pulse output ■ HART or Modbus digital communications ■ Outputs one of: mass flow rate, volume flow rate, or gas standard volume flow rate 			•	•
Compact, integral mounting to sensor with 360 degrees of rotation, or field mount option to a 4-wire or 9-wire Micro Motion sensor. ⁽¹⁾	•		•	
Compact, small-footprint, remote-mount transmitter using 35 mm DIN rail, with connection to either a 4-wire or 9-wire Micro Motion sensor		•		•
Class I, Division 1/Zone 1 local operator interface: <ul style="list-style-type: none"> ■ Standard display supports English, French, Spanish, and German languages ■ Chinese-language display supports English and Chinese languages⁽²⁾ ■ View process variables, handle alarms, control totalizers, meter configuration, and more ■ Interface functions can be customized and password protected 	•		•	
SIS certification: <ul style="list-style-type: none"> ■ Available on the milliamp output with output option codes A or D ■ One meter can be used in SIL 2 applications, and SIL 3 levels can be achieved if redundant meters are used 	•		•	
Compatible with a Smart Wireless THUM Adapter for WirelessHART capability ⁽³⁾	•	•	•	•
Available with Smart Meter Verification	•	•	•	•
Available with filling and dosing application for filling, dosing, and bottling processes. ⁽⁴⁾				•

(1) Models 1700M/P and 2700M/P (stainless steel housing) are only available as remote mount.
 (2) This display is available for purchase in China only, on Model 1700 and 2700 transmitters with analog outputs. This display is certified for ATEX / NEPSI / IECEx Zone 1 use only. For detailed information regarding the approvals options available, see "Hazardous area classifications" on page 13.
 (3) For more information on the Smart Wireless THUM Adapter, see the product data sheet available at www.emersonprocess.com/smartwireless.
 (4) For more information on the Model 1500 transmitter with the filling and dosing application, see the product data sheet available at www.micromotion.com.

Applications

Applications are custom designed programs and software available to offer additional functionality and performance to transmitters. These applications are available through options in the transmitter model code, see the ordering information section for details.

Smart Meter Verification

Provides a quick, complete assessment of a Micro Motion Coriolis meter, determining whether the meter has been affected by erosion, corrosion, or other influences affecting meter calibration. No secondary references are required to perform this operation, and the meter can continue normal process measurement while the test is in progress.

Discrete batch control

- Simple batch control based on totalizer values
- For transmitters with analog or intrinsically safe outputs, the frequency output can be configured as a discrete output.
- For transmitters with configurable I/O, a channel can be configured as a discrete output.

Weights and measures custody transfer

- Physical and software security
- Security-alarm posting
- Mass or volume totalizer that can be configured by the user
- Compliant with MID 2004/22/EC Annex MI-002 and Annex MI-005
- Certified by NTEP and OIML

Concentration measurement

Provides concentration measurement based on either industry-specific or liquid-specific units and relationships. Standard measurement options include:

- Industry-specific:
 - °Brix
 - °Plato
 - °Balling
 - °Baumé at SG60/60
 - Specific gravity
- Liquid-specific:
 - %HFCS
 - Concentration derived from reference density
 - Concentration derived from specific gravity

Additionally, the application can be customized for site-specific concentration measurement (such as %HNO₃, %NaOH).

Petroleum measurement

Adds the following calculations to the standard software:

- Calculates base density (corrected API Gravity) and Ctl (the correction for the effect of temperature on a liquid)
- Calculates gross volume at standard temperature
- Calculates flow-weighted average temperature and flow-weighted average observed gravity (flowing density)

Electrical connections

Connection type	Model 2700	Model 1700	Model 2500	Model 1500
Input/Output	<ul style="list-style-type: none"> Three pairs of wiring terminals for transmitter I/O and communications 	<ul style="list-style-type: none"> Intrinsically safe version: Two pairs of wiring terminals for transmitter outputs Non-intrinsically safe analog outputs (output option A): Three pairs of wiring terminals for transmitter outputs 	<ul style="list-style-type: none"> Three pairs of wiring terminals for transmitter outputs One pair of terminals for digital communications (Modbus/RS-485) 	
Power	<ul style="list-style-type: none"> One pair of wiring terminals accepts AC or DC power One internal ground lug for power-supply ground wiring 		The transmitter has two pairs of terminals for the power connection: <ul style="list-style-type: none"> Either pair accepts DC power The remaining pair can be used for making a jumper connection to a second transmitter 	
Service port	Two clips for temporary connection to the service port		One pair of terminals supports Modbus/RS-485 signal or service port mode. On device power-up, user has 10 seconds to connect in service port mode. After 10 seconds, the terminals default to Modbus/RS-485 mode.	

Notes:

- Each screw terminal connection accepts one or two solid conductors, 14 to 12 AWG (2.5 to 4.0 mm²) or one or two stranded conductors, 22 to 14 AWG (0.34 to 2.5 mm²). Each plug type connector accepts one stranded or solid conductor, 24 to 12 AWG (0.20 to 2.5 mm²).
- For Model 1700/2700 transmitters with an integral core processor (mounting code C), the 4-wire connection between the transmitter and core processor is not normally accessed.

Output summary

Model	Output code	Channel A	Channel B	Channel C	Channel D
1500	A	mA w/ Bell 202 HART	unused	FO/DO	RS-485 HART and Modbus
	C ⁽¹⁾	mA	DO	DO/DI	RS-485Modbus
2500	B	mA w/ Bell 202 HART	configurable to mA, FO, or DO (default mA)	configurable to FO, DO, or DI (default FO)	RS-485 HART and Modbus
	C	mA w/ Bell 202 HART	configurable to mA, FO, or DO (custom)	configurable to FO, DO, or DI (custom)	RS-485 HART and Modbus
1700	A	mA w/ Bell 202 HART	FO/DO	RS485 HART and Modbus	N/A
	D	mA w/ Bell 202 HART	FO/DO	unused	N/A
Legend FO = Frequency/pulse output, scalable to 10,000 Hz DO = Discrete output DI = Discrete input DO = intrinsically safe outputs					

Output summary *(continued)*

Model	Output code	Channel A	Channel B	Channel C	Channel D
2700	A	mA w/ Bell 202 HART	FO/DO	RS485 HART and Modbus	N/A
	B	mA w/ Bell 202 HART	configurable to mA, FO, or DO (default mA)	configurable to FO, DO, or DI (default FO)	N/A
	C	mA w/ Bell 202 HART	configurable to mA, FO, or DO (custom)	configurable to FO, DO, or DI (custom)	N/A
	D	mA w/ Bell 202 HART	FO/DO	mA	N/A
	E	FOUNDATION Fieldbus (FISCO)	unused	unused	N/A
	G	Profibus PA	unused	unused	N/A
	N	FOUNDATION Fieldbus (FNICO)	unused	unused	N/A
	2 ⁽²⁾	mA w/ Bell 202 HART	FO/DO	RS485 HART and Modbus	N/A
	3 ⁽²⁾	mA w/ Bell 202 HART	configurable to mA, FO, or DO (custom)	configurable to FO, DO, or DI (custom)	N/A
	4 ⁽²⁾	mA w/ Bell 202 HART	FO	mA	N/A

Legend
FO = Frequency/pulse output, scalable to 10,000 Hz
DO = Discrete output
DI = Discrete input
BOLD = intrinsically safe outputs

(1) Requires filling and dosing software package.

(2) Output codes 2, 3, and 4 include a Model 2700 transmitter housing with extra conduit connection for 775 THUM mounting capability.

Input/output signal detail

Output code	Outputs and descriptions
<p>All</p>	<p>All</p> <ul style="list-style-type: none"> ■ With mounting codes R, M, and B: One 4-wire sensor signal input connection, intrinsically safe ■ With mounting codes C and P (9-wire remote transmitter): One 9-wire sensor signal input connection, intrinsically safe
<p>A or 2</p> <p>Non-intrinsically safe analog output (with HART and Modbus); Model 1500, Model 1700, and Model 2700 transmitter</p>	<p>One active 4–20 mA output</p> <ul style="list-style-type: none"> ■ Not intrinsically safe ■ Isolated to ±50 VDC from all other outputs and earth ground ■ Maximum load limit: 820 ohms ■ Model 1500 and Model 1700 can report mass flow or volume flow ■ Model 2700 can report mass flow, volume flow, density, temperature, or drive gain ■ Output is linear with process from 3.8 to 20.5 mA, per NAMUR NE43 (February 2003) <p>One active frequency/pulse output</p> <ul style="list-style-type: none"> ■ Not intrinsically safe ■ Can report mass flow or volume flow, which can be used to indicate flow rate or total ■ For Model 1500 and Model 1700, frequency output reports the same flow variable as the mA output ■ For Model 2700, frequency output is independent of mA output ■ Scalable to 10,000 Hz ■ For Model 1500 and 2500, output voltage is +15 VDC ±3% with a 2.2 kohm internal pull-up resistor ■ For Model 1700 and Model 2700, output voltage is +24 VDC ±3% with a 2.2 kohm internal pull-up resistor ■ Output is linear with flow rate to 12,500 Hz ■ Configurable polarity: active high or active low ■ Model 1700 discrete output: Can be configured as a discrete output to report flow direction and flow switch ■ Model 2700 discrete output: Can be configured as a discrete output to report five discrete events, flow direction, flow switch, calibration in progress, or fault. ■ On Model 1700 and Model 2700 transmitters, this can also be configured as a discrete output
<p>Output codes B, C, and 3</p> <p>Non-intrinsically safe configurable output Model 2500 and Model 2700 transmitters. Transmitter has a total of 3 configurable inputs/outputs. Refer to the data below and the information on page 10 for the ways that these 3 inputs/outputs can be configured</p>	<p>One or two active 4–20 mA outputs</p> <ul style="list-style-type: none"> ■ Not intrinsically safe ■ Isolated to ±50 VDC from all other outputs and earth ground ■ Maximum load limit of mA1: 820 ohms; of mA2: 420 ohms ■ Can report mass flow, volume flow, density, temperature, or drive gain ■ Output is linear with process from 3.8 to 20.5 mA, per NAMUR NE43 (June 1994) <p>One or two active or passive frequency/pulse outputs</p> <ul style="list-style-type: none"> ■ Not intrinsically safe ■ Can report mass flow or volume flow, which can be used to indicate flow rate or total ■ If configured as a dual pulse output, the channels are electrically isolated but not independent (see custody transfer note below) ■ Scalable to 10,000 Hz ■ If active, output voltage is +15 VDC ±3% with a 2.2 kohm internal pull-up resistor ■ If passive, output voltage is 30 VDC maximum, 24 VDC typical, sinking up to 500 mA at 30 VDC. ■ Output is linear with flow rate to 12,500 Hz

Input/output signal detail (continued)

Output code	Outputs and descriptions
Output codes B, C, and 3 (continued)	<p>One or two active or passive discrete outputs</p> <ul style="list-style-type: none"> ■ Not intrinsically safe ■ Can report five discrete events, flow switch, forward/reverse flow, calibration in progress, or fault ■ If active, output voltage is +15 VDC \pm3% with a 2.2 kohm internal pull-up resistor ■ If passive, output voltage is 30 VDC maximum, 24 VDC typical, sinking up to 500 mA at 30 VDC <p>One discrete input</p> <ul style="list-style-type: none"> ■ Can be configured for active or passive power ■ Not intrinsically safe ■ Active power +15 VDC, 7 mA maximum source current ■ Passive power +3–30 VDC maximum ■ Can start/stop totals and inventories, reset all totals, reset mass total, reset volume total, start sensor zero, or initiate multiple actions <p>Custody transfer using double-pulse frequency output</p> <p>The transmitter can be configured for two frequency outputs. The second output can be phase-shifted –90, 0, 90, or 180 degrees from the first output, or the dual-pulse output can be set to quadrature mode</p>
Output codes E and G Intrinsically safe FOUNDATION fieldbus and PROFIBUS-PA Model 2700 transmitters	<p>One FOUNDATION fieldbus H1 or PROFIBUS-PA output</p> <ul style="list-style-type: none"> ■ FOUNDATION fieldbus and PROFIBUS-PA wiring is intrinsically safe with an intrinsically safe power supply ■ The transmitter fieldbus circuit is passive, and draws power from the fieldbus segment. Current draw from the fieldbus segment is 13 mA ■ Manchester-encoded digital signal conforms to IEC 61158-2
Output code N Non-incendive FOUNDATION fieldbus transmitters.	<p>One FOUNDATION fieldbus H1 output</p> <ul style="list-style-type: none"> ■ FOUNDATION fieldbus wiring is non-incendive ■ The transmitter fieldbus circuit is passive, and draws power from the fieldbus segment. Current draw from the fieldbus segment is 13 mA ■ Manchester-encoded digital signal conforms to IEC 61158-2

Input/output signal detail (continued)

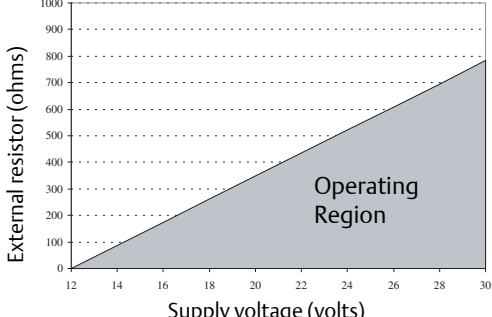
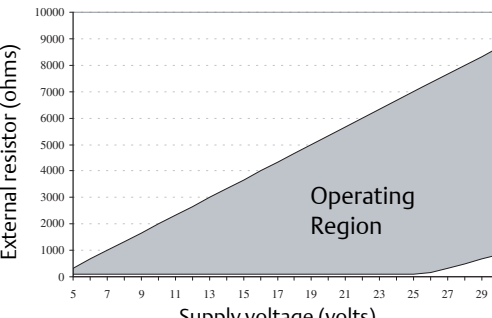
Output code	Outputs and descriptions
<p>Output codes D and 4</p> <p>Intrinsically safe Model 1700 and Model 2700 transmitters</p>	<p>One intrinsically safe passive 4–20mA output (two with Model 2700)</p> <ul style="list-style-type: none"> ■ Maximum input voltage: 30 VDC, 1 watt maximum ■ Maximum load limit: see chart below ■ Model 1700 can report mass flow or volume flow; Model 2700 can report mass flow, volume flow, density, temperature, or drive gain ■ Entity parameters: $U_i = 30$ VDC, $I_i = 300$ mA, $P_i = 1$ W, $C_i = 0.0005$ μF, $L_i =$ Less than 0.05 mH ■ Output is linear with process from 3.8 to 20.5 mA, per NAMUR NE43 (June 1994) <p style="text-align: center;">mA Output Load Resistance Value $R_{max} = (V_{supply} - 12)/0.023^*$</p> <p><small>*If communicating with HART a minimum of 250 ohms and 17.75 V supply is needed</small></p> 
	<p>One intrinsically safe frequency/pulse output or configurable frequency/pulse/discrete output</p> <ul style="list-style-type: none"> ■ Maximum input voltage: 30 VDC, 0.75 watt maximum ■ Maximum load limit: see chart below ■ Can report mass flow or volume flow, which can be used to indicate flow rate or total ■ For Model 1700, frequency output reports the same flow variable as the mA output ■ For Model 2700, frequency output is independent of the mA output ■ Scalable to 10,000 Hz ■ Entity parameters: $U_i = 30$ VDC, $I_i = 100$ mA, $P_i = 0.75$ W, $C_i = 0.0005$ μF, $L_i =$ Less than 0.05 mH ■ Output is linear with flow rate to 12,500 Hz <p style="text-align: center;">Frequency Output Load Resistance Value $R_{max} = (V_{supply} - 4)/0.003$ $R_{min} = (V_{supply} - 25)/0.006$</p> <p><small>*Absolute minimum = 100 ohms for $V_{supply} < 25.6$ volts</small></p> 

Series 2000 transmitters with configurable I/O functionality

The Series 2000 transmitter with configurable inputs and outputs is designed to increase transmitter flexibility and reduce the number of transmitter variations required in inventory. The table below shows the various configuration options that can be produced with the configurable I/O output option.

Channel assignments for Series 2000 transmitters with configurable I/O (output option codes B, C, and 3)

- When output code B is selected, the transmitter ships with channels assigned to default values.
- When output codes C or 3 are selected, the transmitter is custom configured prior to shipment. Output code 3 is only available with Model 2700 transmitters.

Channel	Terminals		Configuration options	Default variable assignment	Power
	2700	2500			
A	1 & 2	21 & 22	mA output with Bell 202/HART (only)	Mass flow	Active
B	3 & 4	23 & 24	mA output (default)	Density	Active
			Frequency output ⁽¹⁾	Mass flow	Active or passive ⁽²⁾
			Discrete output	Fwd/rev flow	Active or passive
C	5 & 6	31 & 32	Frequency output (default) ⁽¹⁾	Mass flow	Active or passive
			Discrete output	Flow switch	Active or passive
			Discrete input	None	Active or passive

(1) If channels B and C are both configured as a frequency output (dual pulse), both outputs are generated from the same signal. The outputs are electrically isolated but not independent.

(2) The user must supply power when a channel is set to passive power.

Digital communications

Output type	Outputs and descriptions
All	<ul style="list-style-type: none"> ■ One service port can be used for temporary connection only ■ Uses RS-485 Modbus signal, 38.4 kilobaud, one stop bit, no parity
HART/RS-485, Modbus/RS-485	<ul style="list-style-type: none"> ■ Models/output codes: <ul style="list-style-type: none"> - All models with output code A, except when ordered with display code 8 - Model 2500 with output codes B and C - Model 2700 with output code 2 ■ One RS-485 output can be used for direct connection to a HART or Modbus host system; accepts data rates between 1200 baud and 38.4 kilobaud ■ HART revision 5 as default, selectable to HART revision 7
HART/Bell 202	<ul style="list-style-type: none"> ■ Models/output codes: Model 1500 with output code A, Models 1700 and 2500 with output codes A, B, C, and D. Model 2700 with output codes A, B, C, D, 2, 3, and 4 ■ HART Bell 202 signal is superimposed on the primary milliamp output, and is available for host system interface. Frequency 1.2 and 2.2 kHz, Amplitude: to 1.0 mA, 1200 baud, Requires 250 to 600 ohms load resistance ■ HART revision 5 as default, selectable to HART revision 7

Digital communications (continued)

Output type	Outputs and descriptions
FOUNDATION fieldbus	<ul style="list-style-type: none"> ■ Models/output codes: <ul style="list-style-type: none"> - Model 2700 with output code E - Model 2700 with output code N ■ Transmitters are registered with the Fieldbus Foundation, and conform to the FOUNDATION fieldbus H1 protocol specification. Transmitters with output code E are FISCO certified. Transmitters with output code N are FNICO certified ■ FISCO: <ul style="list-style-type: none"> - Field device in compliance with EN 60079-27:2006, IEC 60079-27:2005-04, and TS-60079-27:2002 - $U_i = 30\text{ V}$, $I_i = 380\text{ mA}$, $P_i = 5.32\text{ W}$, $C_i = 0.0005\text{ }\mu\text{F}$, $L_i = \text{Less than } 0.05\text{ mH}$ ■ FNICO: Field device in compliance with EN 60079-27:2006 and IEC 60079-27:2005-04
PROFIBUS-PA	<ul style="list-style-type: none"> ■ Model 2700 with output code G ■ Transmitters are registered with the Profibus Organization, and fulfill the requirements of the PROFIBUS-PA Profile for Process Control Devices. Compatible for configuration with Siemens® Simatic® PDM ■ FISCO: <ul style="list-style-type: none"> - Field device in compliance with EN 60079-27:2006, IEC 60079-27:2005-04, and TS-60079-27:2002 - $U_i = 30\text{ V}$, $I_i = 380\text{ mA}$, $P_i = 5.32\text{ W}$, $C_i = 0.0005\text{ }\mu\text{F}$, $L_i = \text{Less than } 0.05\text{ mH}$

Model 2700 transmitter with FOUNDATION fieldbus

Fieldbus software functionality

Model 2700 FOUNDATION fieldbus software is designed to permit remote testing and configuration of the transmitter using the DeltaV™ Fieldbus Configuration Tool, or other FOUNDATION fieldbus compliant hosts. The Coriolis sensor signal is channelled through the flowmeter to the control room and the FOUNDATION fieldbus configuration device.

Transducer blocks

Transducer blocks hold data from the Coriolis sensor, including process variables, configuration, calibration, and diagnostics.

The Model 2700 transmitter with FOUNDATION fieldbus provides up to seven transducer blocks:

- Measurement - For process variables
- Calibration - For calibration information
- Diagnostic- For diagnosing problems and running diagnostic tests (including the Smart Meter Verification procedure, if the transmitter is paired with an enhanced core processor)
- Device Information - For data such as sensor type
- Local Display - For configuring the transmitter display
- API - For petroleum measurement calculations using API MPMS Chapter 11.1
- Concentration Measurement
 - For complex density and concentration calculations (e.g., %HFCS, SG60/60)

Resource block

The resource block contains physical device information, including available memory, manufacturer identification, type of device, and features.

Analog input function blocks

The Analog Input (AI) function block processes the measurement from the Coriolis sensor and makes it available to other function blocks. It also allows filtering, alarm handling, and engineering unit changes. Each of the four Model 2700 AI blocks can be assigned to one of 19 available variables.

Analog output block

The AO function block assigns an output value to a field device through a specified channel. The block supports mode control, signal status calculation, and simulation. The AO block can report either pressure from an external pressure source or temperature from an external temperature source.

Discrete input block

One permanent Discrete Input (DI) function block can be assigned to any of the discrete input variable channels in the transducer block. The DI block channels are: forward/reverse indication, zero in progress, fault condition indication, and meter verification failure.

Discrete output block

One permanent Discrete Output (DO) function block can be assigned to any of the discrete output variable channels in the transducer block. The DO block channels are: start sensor zero, reset mass total, reset volume total, reset API reference (standard) volume total, reset all process totals, reset concentration measurement reference volume total, reset concentration measurement net mass total, reset concentration measurement net volume total, start/stop all totals, increment concentration measurement curve, reset gas standard volume total, and start meter verification in continuous measurement mode.

Proportional integral derivative block

The optional proportional integral derivative (PID) function block combines all the necessary logic to perform proportional/integral/derivative control. The block supports mode control, signal scaling and limiting, feed forward control, override tracking, alarm limit detection, and signal status propagation.

Integrator block

The integrator block provides functionality for the transmitter totalizers. Any process total can be selected and reset.

Diagnostics and service

Model 2700 transmitters automatically perform continuous self diagnostics. Using the Diagnostic transducer block, the user can perform on-line testing of the transmitter and sensor. Diagnostics are event driven and do not require polling for access.

PlantWeb® Field Diagnostic is supported. The diagnostic information is based on NAMUR NE 107 standard.

Power supply

Model	Description
<p>Model 1700 and Model 2700</p>	<ul style="list-style-type: none"> ■ Self switching AC/DC input, automatically recognizes supply voltage ■ Complies with low voltage directive 2006/95/EC per EN 61010-1 (IEC 61010-1) with amendment 2; Installation (Overvoltage) Category II, Pollution Degree 2 ■ AC power: 85 to 265 VAC, 50/60 Hz, 6 watts typical, 11 watts maximum ■ DC power: <ul style="list-style-type: none"> - 18 to 100 VDC, 6 watts typical, 11 watts maximum - Minimum 22 VDC with 1000 feet of 18 AWG (300 meters of 0.8 mm²) power-supply cable - At startup, transmitter power source must provide a minimum of 1.5 amperes of short-term current at a minimum of 18 volts at the transmitter’s power input terminals ■ Fuse: IEC 127-1.25 non-serviceable fuse, slow blow
<p>Model 1500 and Model 2500</p>	<ul style="list-style-type: none"> ■ Transmitter power supply meets Installation (Overvoltage) Category II, Pollution Degree 2 requirements ■ DC power: <ul style="list-style-type: none"> - Minimum 19.2 to 28.8 VDC, 6.3 watts - At startup, transmitter power source must provide a minimum of 1.0 amperes of short-term current per transmitter - Length and conductor diameter of the power cable must be sized to provide 19.2 VDC minimum at the power terminals, at a load current of 330 mA ■ Fuse: IEC 1.6A non-serviceable fuse, slow blow

Environmental limits

Environmental factor		°F	°C
Ambient temperature limits	Model 1700/2700 ⁽¹⁾⁽²⁾	Operating	-40 to +140
		Storage	-40 to +140
	Model 1500/2500 ⁽³⁾	Operating	-40 to +131
		Storage	-40 to +185
Humidity limits	5 to 95% relative humidity, non-condensing at 140 °F (60 °C)		
Vibration limits	Meets IEC 68.2.6, endurance sweep, 5 to 2000 Hz, 50 sweep cycles at 1.0 g		
Housing rating	Model 1700/2700	NEMA 4X (IP66)	
	Model 1500/2500	None	

- (1) Display responsiveness decreases, and display may become difficult to read, below -4 °F (-20 °C). Above 131 °F (55 °C), some darkening of display might occur.
- (2) ATEX approvals require limiting ambient temperature to 140 °F (60 °C) on Model 1700/Model 2700 core processors (for example, Model 1700C/Model 2700C); UL approvals require limiting ambient temperature to below 140 °F (60 °C).
- (3) If the temperature is above 131 °F (55 °C), and you are mounting multiple transmitters, the transmitters must be at least 8.5 mm apart.

Environmental effects

EMI effects

- Complies with EMC directive 2004/108/EC per EN 61326 Industrial
- Complies with NAMUR NE-21 (22.08.2007). With the exception of voltage dip when powered by 24 VDC on 1700/2700 transmitters

Ambient temperature effect

- On analog outputs: ±0.005% of span per °C change from temperature at which the outputs were trimmed

Hazardous area classifications

Model 1700 and Model 2700

UL, CSA, and CSA-US

- Ambient temperature is limited to -40°F (-40°C) to 140 °F (60 °C) for UL and CSA compliance.
- Class I, Div. 1, Groups C and D. Class II, Div. 1, Groups E, F, and G explosion proof (when installed with approved conduit seals). Otherwise, Class I, Div. 2, Groups A, B, C, and D.
- Provides nonincendive sensor outputs for use in Class I, Div. 2, Groups A, B, C, and D; or intrinsically safe sensor outputs for use in Class I, Div. 1, Groups C and D or Class II, Div. 1, Groups E, F, and G.

IECEX

- Ambient temperature is limited to -40°F (-40°C) to 131 °F (55 °C) for IECEX compliance. Transmitters with output codes A, B, C, D, E, G, and N are rated for increased safety or flameproof with approved cable glands.

Output option	Code	Approval		
Analog outputs	A	Flameproof	Ex d [ib] IIB+H ₂ T5 Gb	Standard display or Chinese-language display
			Ex d [ib] IIC T5 Gb	No display or IIC display
Configurable I/O	B or C	Flameproof	Ex d [ib] IIB+H ₂ T5 Gb	Standard display
			Ex d [ib] IIC T5 Gb	No display or IIC display
FOUNDATION fieldbus (non-intrinsically safe)	N	Flameproof	Ex d [ib] IIB+H ₂ T5 Gb	Standard display
			Ex d [ib] IIC T5 Gb	No display or IIC display
Intrinsically safe	D	Flameproof	Ex d [ia Ga] [ib] IIB+H ₂ T5 Gb	Standard display
			Ex d [ia Ga] [ib] IIC T5 Gb	No display or IIC display
FOUNDATION fieldbus (IS), or PROFIBUS-PA ⁽¹⁾	E or G	Flameproof	Ex d [ia Ga] [ib] IIB+H ₂ T5 Gb	Standard display
			Ex d [ia Ga] [ib] IIC T5 Gb	No display or IIC display
Intrinsically safe	D	Increased Safety	Ex de [ia Ga] [ib] IIB+H ₂ T5 Gb	Standard display
			Ex de [ia Ga] [ib] IIC T5 Gb	No display or IIC display
FOUNDATION fieldbus (IS), or PROFIBUS-PA ⁽¹⁾	E or G	Increased Safety	Ex de [ia Ga] [ib] IIB+H ₂ T5 Gb	Standard display
			Ex de [ia Ga] [ib] IIC T5 Gb	No display or IIC display
I.S. with WirelessHART	4	Increased safety ⁽²⁾	Ex de [ia Ga] [ib] IIB+H ₂ T4 Gb	Standard display
			Ex de [ia Ga] [ib] IIC T4 Gb	No display or IIC display
Non-I.S. with WirelessHART	2 or 3	non-Sparking	Ex nA de [ib Gb] IIB+H ₂ T4 Gc	Standard display
			Ex nA de [ib Gb] IIC T4 Gc	No display or IIC display

(1) Output codes E and G are FISCO field devices in compliance with IEC 60079-11:2012.
 (2) Models 1700M, 1700P, 2700M, and 2700P (stainless steel housing) are limited to flameproof (Exd) rating.

ATEX

Ambient temperature is limited to below 140 °F (60 °C) for ATEX compliance. Transmitters with output codes A, B, C, D, E, G, and N are rated for increased safety or flameproof with approved cable glands.

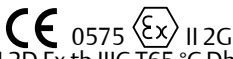
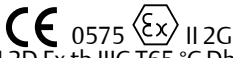
Output option	Code	Approval			
Analog outputs	A	 II 2D Ex tb IIIC T65 °C Db IP66/IP67			
			Increased safety ⁽¹⁾	Ex de [ib] IIB+H ₂ T5 Gb	Standard display or Chinese-language display
				Ex de [ib] IIC T5 Gb	No display or IIC display
			Flameproof	Ex d [ib] IIB+H ₂ T5 Gb	Standard display or Chinese-language display
Ex d [ib] IIC T5 Gb	No display or IIC display				
Configurable I/O	B or C	 II 2D Ex tb IIIC T65 °C Db IP66/IP67			
			Increased safety ⁽¹⁾	Ex de [ib] IIB+H ₂ T5 Gb	Standard display
				Ex de [ib] IIC T5 Gb	No display or IIC display
			Flameproof	Ex d [ib] IIB+H ₂ T5 Gb	Standard display
Ex d [ib] IIC T5 Gb	No display or IIC display				

Output option	Code	Approval		
FOUNDATION fieldbus (non-intrinsically safe)	N	 II 2D Ex tb IIC T65 °C Db IP66/IP67		
		Increased safety ⁽¹⁾	Ex de [ib] IIB+H ₂ T5 Gb	Standard display
			Ex de [ib] IIC T5 Gb	No display or IIC display
		Flameproof	Ex d [ib] IIB+H ₂ T5 Gb	Standard display
Ex d [ib] IIC T5 Gb	No display or IIC display			
Intrinsically safe	D	 II 2D Ex tb IIC T65 °C Db IP66/IP67		
		Increased safety ⁽¹⁾	Ex de [ia Ga] [ib] IIB+H ₂ T5 Gb	Standard display
			Ex de [ia Ga] [ib] IIC T5 Gb	No display or IIC display
		Flameproof	Ex d [ia Ga] [ib] IIB+H ₂ T5 Gb	Standard display
Ex d [ia Ga] [ib] IIC T5 Gb	No display or IIC display			
FOUNDATION fieldbus (IS), or PROFIBUS-PA ⁽²⁾	E or G	 II 2D Ex tb IIC T65 °C Db IP66/IP67		
		Increased safety ⁽¹⁾	Ex de [ia Ga] [ib] IIB+H ₂ T5 Gb	Standard display
			Ex de [ia Ga] [ib] IIC T5 Gb	No display or IIC display
		Flameproof	Ex d [ia Ga] [ib] IIB+H ₂ T5 Gb	Standard display
Ex d [ia Ga] [ib] IIC T5 Gb	No display or IIC display			
I.S. with WirelessHART	4	 II (1) 2G		
		Increased safety ⁽¹⁾	Ex de [ia Ga] [ib] IIB+H ₂ T4 Gb	Standard display
			Ex de [ia Ga] [ib] IIC T4 Gb	No display or IIC display
Non-I.S. with WirelessHART	2 or 3	 II (2) 3G		
		non-Sparking	Ex nA de [ib Gb] IIB+H ₂ T4 Gc	Standard display
			Ex nA de [ib Gb] IIC T4 Gc	No display or IIC display

(1) Models 1700M, 1700P, 2700M, and 2700P (stainless steel housing) are limited to flameproof (Exd) rating.

(2) Output codes E and G are FISCO field devices in compliance with EN 60079-11:2012.

NEPSI

Output option	Code	Approval		
Analog outputs	A	Increased safety ⁽¹⁾	Ex de [ib] IIB+H ₂ T5 Gb	Standard display or Chinese-language display
			Ex de [ib] IIC T5 Gb	No display or IIC display
		Flameproof	Ex d [ib] IIB+H ₂ T5 Gb	Standard display or Chinese-language display
			Ex d [ib] IIC T5 Gb	No display or IIC display

Output option	Code	Approval		
Configurable I/O	B or C	Increased safety ⁽¹⁾	Ex de [ib] IIB+H ₂ T5 Gb	Standard display
			Ex de [ib] IIC T5 Gb	No display or IIC display
		Flameproof	Ex d [ib] IIB+H ₂ T5 Gb	Standard display
			Ex d [ib] IIC T5 Gb	No display or IIC display
Intrinsically safe	D	Increased safety ⁽¹⁾	Ex de [ia/ib] IIB+H ₂ T5 Gb	Standard display
			Ex de [ia/ib] IIC T5 Gb	No display or IIC display
		Flameproof	Ex d [ia/ib] IIB+H ₂ T5 Gb	Standard display
			Ex d [ia/ib] IIC T5 Gb	no display or IIC display
FOUNDATION fieldbus (IS), or PROFIBUS-PA ⁽¹⁾	E or G	Increased safety ⁽¹⁾	Ex de [ia/ib] IIB+H ₂ T5 Gb	Standard display
			Ex de [ia/ib] IIC T5 Gb	No display or IIC display
		Flameproof	Ex d [ia/ib] IIB+H ₂ T5 Gb	Standard display
			Ex d [ia/ib] IIC T5 Gb	No display or IIC display

(1) Output codes E and G are FISCO field devices in compliance with TS-60079-27:2005.

INMETRO



INMETRO Certificate No. TÜV 11.0372 X

Output option	Code	Approval		
Analog outputs	A	Increased safety	Ex de [ib] IIB+H ₂ T5 Gb IP66/67	Standard display
			Ex de [ib] IIC T5 Gb IP66/67	No display or IIC display
		Flameproof	Ex d [ib] IIB+H ₂ T5 Gb IP66/67	Standard display
			Ex d [ib] IIC T5 Gb IP66/67	No display or IIC display
Configurable I/O	B or C	Increased safety	Ex de [ib] IIB+H ₂ T5 Gb IP66/67	Standard display
			Ex de [ib] IIC T5 Gb IP66/67	No display or IIC display
		Flameproof	Ex d [ib] IIB+H ₂ T5 Gb IP66/67	Standard display
			Ex d [ib] IIC T5 Gb IP66/67	No display or IIC display

Output option	Code	Approval		
Intrinsically safe	D	Increased safety	Ex de [ia/ib] IIB+H ₂ T5 Ga/Gb IP66/67	Standard display
			Ex de [ia/ib] IIC T5 Ga/Gb IP66/67	No display or IIC display
		Flameproof	Ex d [ia/ib] IIB+H ₂ T5 Ga/Gb IP66/67	Standard display
			Ex d [ia/ib] IIC T5 Ga/Gb IP66/67	No display or IIC display
FOUNDATION fieldbus (IS), or PROFIBUS-PA ⁽¹⁾	E or G	Increased safety	Ex de [ia/ib] IIB+H ₂ T5 Ga/Gb IP66/67	Standard display
			Ex de [ia/ib] IIC T5 Ga/Gb IP66/67	No display or IIC display
		Flameproof	Ex d [ia/ib] IIB+H ₂ T5 Ga/Gb IP66/67	Standard display
			Ex d [ia/ib] IIC T5 Ga/Gb IP66/67	No display or IIC display
I.S with WirelessHART	4	Increased safety	Ex de [ia/ib] IIB+H ₂ T4 Ga/Gb IP66/67	Standard display
			Ex de [ia/ib] IIC T4 Ga/Gb IP66/67	No display or IIC display
Non-I.S. with WirelessHART	2 or 3	non-Sparking	Ex nA de [ib] IIB+H ₂ T4 Gb IP66/67	Standard display
			Ex nA de [ib] IIC T4 Gb IP66/67	No display or IIC display

(1) Output codes E and G are FISCO field devices in compliance with TS-60079-27:2002.

Model 1500 and 2500

CSA and CSA-US

- Transmitter (when installed in a suitable enclosure): Class I, Div. 2, Groups A, B, C, and D.
- Sensor, including wiring to sensor: Class I, Div. 1, Groups C and D or Class II, Div. 1, Groups E, F, and G.

ATEX

- Ambient temperature is limited to -40 to +131 °F (-40 to +55 °C) for ATEX compliance.
- **CE** 0575 Ex II(2) G [EEx ib] IIB/IIC Operating conditions: Environmental.

Marine approval classifications

Marine approval	Country
Det Norske Veritas- Germanischer Lloyd (Models 1500 and 2500 only)	Norway-Germany
American Bureau of Shipping (all models)	USA

Physical specifications

Model 1700 and Model 2700

Specification	Value
Housing	<ul style="list-style-type: none"> ■ Polyurethane-painted cast aluminum or CF3M stainless steel; NEMA 4X (IP66)
Weight⁽¹⁾	<ul style="list-style-type: none"> ■ Painted aluminum, 4-wire remote: <ul style="list-style-type: none"> - with display: 8 lb (4 kg) - without display: 7 lb (3kg) ■ Painted aluminum, 9-wire remote: <ul style="list-style-type: none"> - With display: 14 lb (6 kg) - Without display: 13 lb (6 kg) ■ Stainless steel: <ul style="list-style-type: none"> - With display: 21 lb (10 kg) - Without display: 20 lb (9 kg) ■ Option with Smart Wireless THUM Adapter: Add 0.65 lb (0.29 kg) to transmitter weight
Terminal compartments	<ul style="list-style-type: none"> ■ Output terminals are physically separated from the power and service-port terminals.
Cable gland entrances	<ul style="list-style-type: none"> ■ 1/2"–14 NPT or M20 × 1.5 female conduit ports for outputs and power supply ■ 3/4"–14 NPT female conduit port for sensor/core processor cable ■ Painted aluminum transmitters with WirelessHART, and all stainless steel transmitters, have one additional 1/2"–14 NPT conduit opening
Mounting	<ul style="list-style-type: none"> ■ Integral or remote mounting options (stainless steel versions are always remote mounted) ■ May be remotely connected to any 4-wire or 9-wire Micro Motion sensor ■ Remote-mount transmitters: <ul style="list-style-type: none"> - Painted aluminum versions include a 304L stainless steel mounting bracket; hardware for installing the transmitter on the mounting bracket is included - Stainless steel versions include a 316 stainless steel mounting bracket and hardware ■ Transmitter can be rotated on the sensor or the mounting bracket, 360 degrees, in 90-degree increments.

Model 1700 and Model 2700 (continued)

Specification	Value		
Maximum cable lengths between sensor and transmitter⁽²⁾	Cable type	Wire gauge	Maximum length
	■ Micro Motion 9-wire	Not applicable	60 feet (20 meters)
	■ Micro Motion 4-wire	Not applicable	1000 feet (300 meters)
	■ User-supplied 4-wire:		
	- Power wires (VDC)	22 AWG (0.34 mm ²)	300 feet (90 meters)
		20 AWG (0.5 mm ²)	500 feet (150 meters)
	18 AWG (0.8 mm ²)	1000 feet (300 meters)	
	- Signal wires (RS-485)	22 AWG (0.34 mm ²) or larger	1000 feet (300 meters)
Standard interface/display	<ul style="list-style-type: none"> ■ Segmented 2-line display with LCD screen with optical controls and flowmeter-status LED is standard; suitable for hazardous area installation ■ Available in both backlit and non-backlit versions ■ Depending on purchase option, transmitter housing cover has non-glass or non-glare tempered glass lens ■ To facilitate various mounting orientations, the display can be rotated on transmitter, 360 degrees, in 90-degree increments ■ LCD line 1 lists the process variable; LCD line 2 lists engineering unit of measure ■ Display supports English, French, German, and Spanish languages ■ Display controls feature optical switches that are operated through the glass with a red LED for visual feedback to confirm when a “button” is pressed 		
Chinese-language interface/display⁽³⁾	<ul style="list-style-type: none"> ■ Six-line graphical display optimized for Chinese-language support. Has LCD screen with optical controls and flowmeter-status LED; suitable for hazardous area installation ■ Available in both backlit and non-backlit versions ■ Transmitter housing cover has non-glare tempered-glass lens ■ To facilitate various mounting orientations, the display can be rotated on transmitter, 360 degrees, in 90-degree increments ■ Display shows the process variable name, value, and units of measure ■ Display supports English and Chinese languages ■ Display controls feature three optical switches that are operated through the lens with a red LED for visual feedback to confirm when a “button” is pressed. ■ Pressing specific optical switch combinations can access the display menu, change the language display, lock/unlock display access, and return to the process variables view 		
Display functions⁽⁴⁾	<ul style="list-style-type: none"> ■ Operational: View process variables; start, stop, and reset totalizers; view and acknowledge alarms. ■ Off-line: Zero flowmeter, Smart Meter Verification, simulate outputs, change measurement units, configure outputs, and set RS-485 communications options. ■ Status LED: Three-color LED status light on display panel indicates flowmeter condition at a glance. 		

(1) For transmitters integrally mounted to a sensor, you may need to add the weight of the transmitter to the sensor. Refer to the sensor product data sheet.
 (2) Where 4-wire cable is required, Micro Motion recommends the use of Micro Motion 4-wire cable. Depending on the specific model number ordered, 10 ft (3 m) of cable (4-wire or 9-wire) may be included (see ordering information for details). For longer cable lengths, contact Micro Motion.
 (3) This option is available for purchase in China only.
 (4) Applies to all display options.

Model 1500/2500

Weight	0.52 lb (0.24 kg)		
Mounting	<ul style="list-style-type: none"> ■ Mounted on 35 mm rail ■ Rail must be grounded ■ May be remotely connected to any Micro Motion sensor ■ Requires standard 4-wire twisted, shielded signal cable, up to 1000 feet (300 meters) in length, between the sensor and the transmitter. (If the core processor is remotely mounted from the sensor, the maximum length of the 9-wire signal cable between the sensor and the remote core processor is 60 feet [20 meters]) 		
Maximum cable lengths between sensor and transmitter⁽¹⁾	Cable type	Wire gauge	Maximum length
	■ Micro Motion 9-wire	Not applicable	60 feet (20 meters)
	■ Micro Motion 4-wire	Not applicable	1000 feet (300 meters)
	■ User-supplied 4-wire:		
- Power wires (VDC)	22 AWG (0.34 mm ²) 20 AWG (0.5 mm ²) 18 AWG (0.8 mm ²)	300 feet (90 meters) 500 feet (150 meters) 1000 feet (300 meters)	
- Signal wires (RS-485)	22 AWG (0.34 mm ²) or larger	1000 feet (300 meters)	
Status LED	Three-color status LED on face of transmitter indicates flowmeter condition at a glance, using a solid green, yellow, or red light. Zero in progress is indicated by a flashing yellow light		
Zero button	A zero button on the face of the transmitter can be used to start the transmitter zero procedure		

(1) Where 4-wire cable is required, Micro Motion recommends the use of Micro Motion 4-wire cable.

Dimensions

Model 1700/2700 4-wire remote-mount transmitter with display – painted aluminum housing

Dimensions in inches (mm)

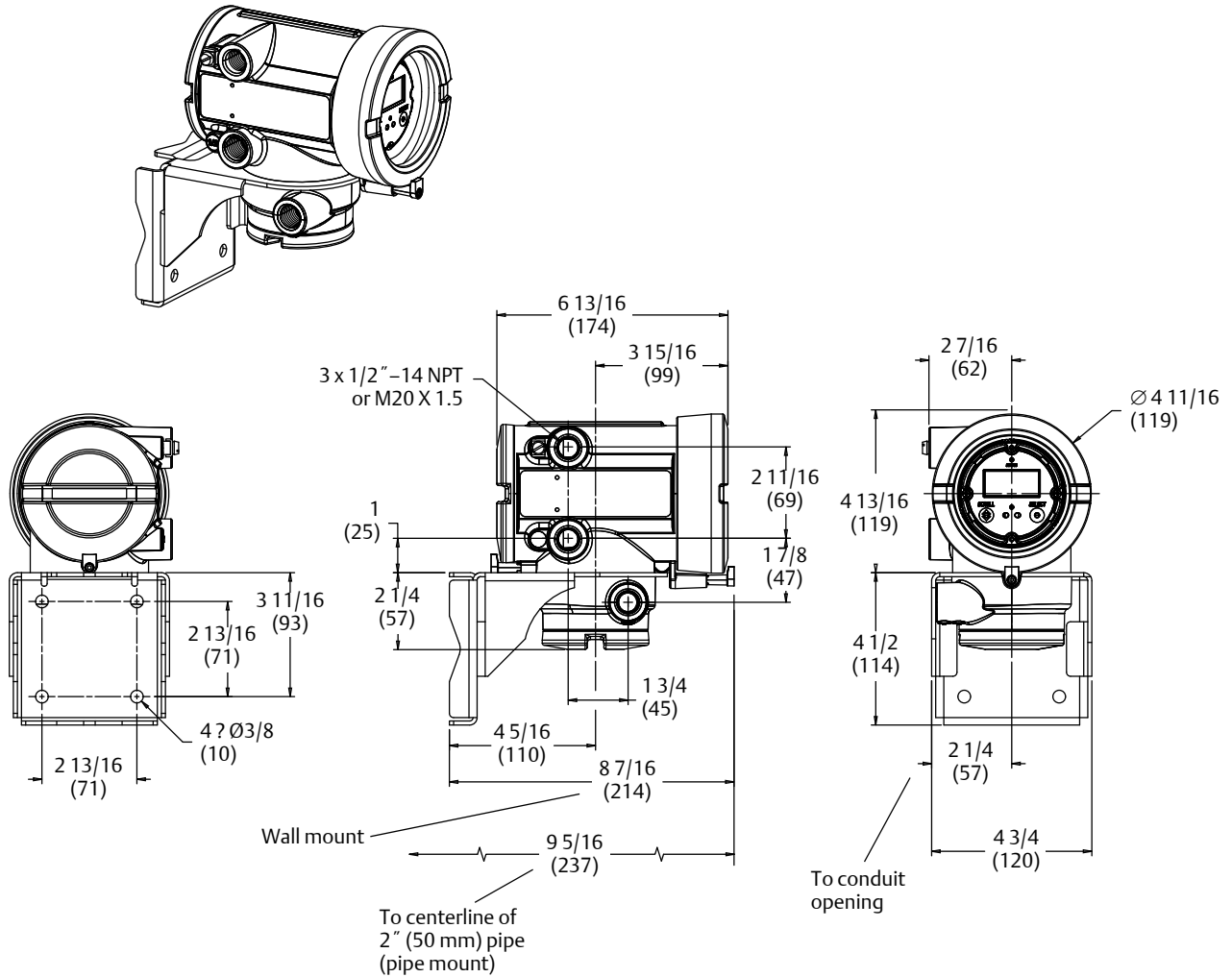

For dimensions of integrally mounted transmitter and sensor, refer to the sensor product data sheet.

Model 1700/2700 4-wire remote-mount transmitter without display – painted aluminum housing

Dimensions in inches (mm)

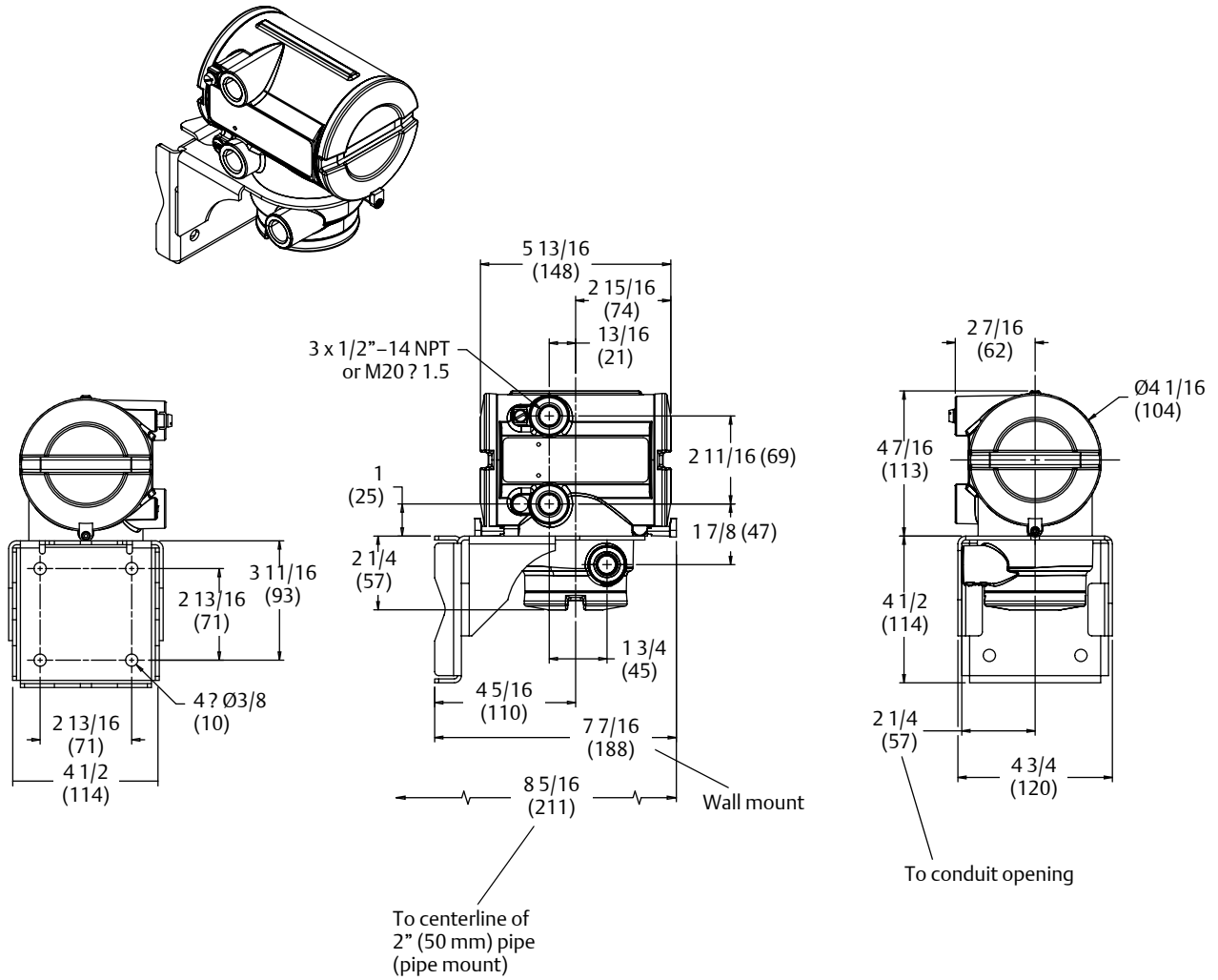

For dimensions of integrally mounted transmitter and sensor, refer to the sensor product data sheet.

Model 1700/2700 9-wire remote-mount transmitter and core processor assembly with display – painted aluminum housing

Dimensions in inches (mm)

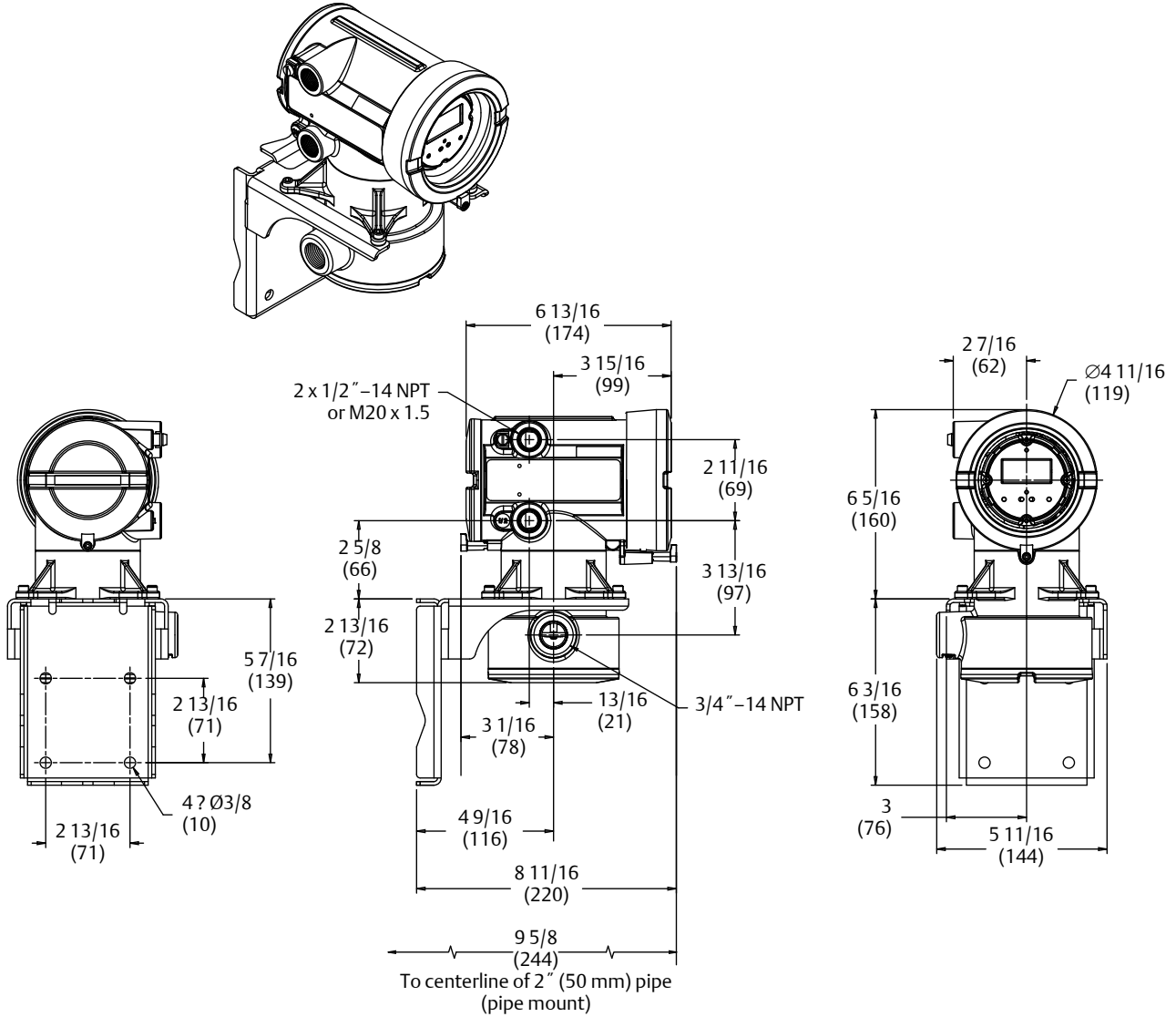

For dimensions of integrally mounted transmitter and sensor, refer to the sensor product data sheet.

Model 1700/2700 9-wire remote-mount transmitter and core processor assembly without display – painted aluminum housing

Dimensions in inches (mm)

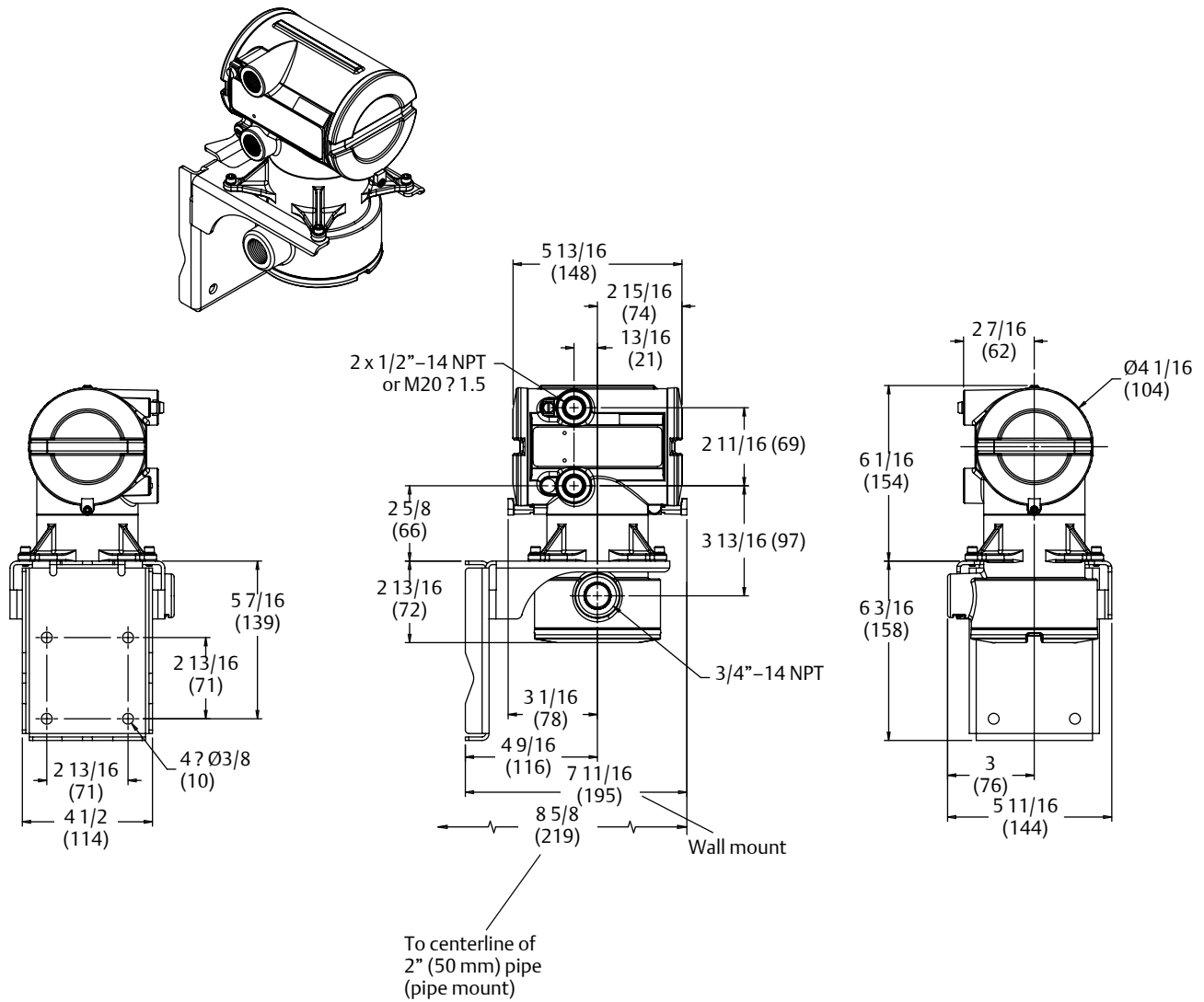

For dimensions of integrally mounted transmitter and sensor, refer to the sensor product data sheet.

Model 1700/2700 4-wire and 9-wire remote mount transmitter – stainless steel housing

Dimensions in inches (mm)

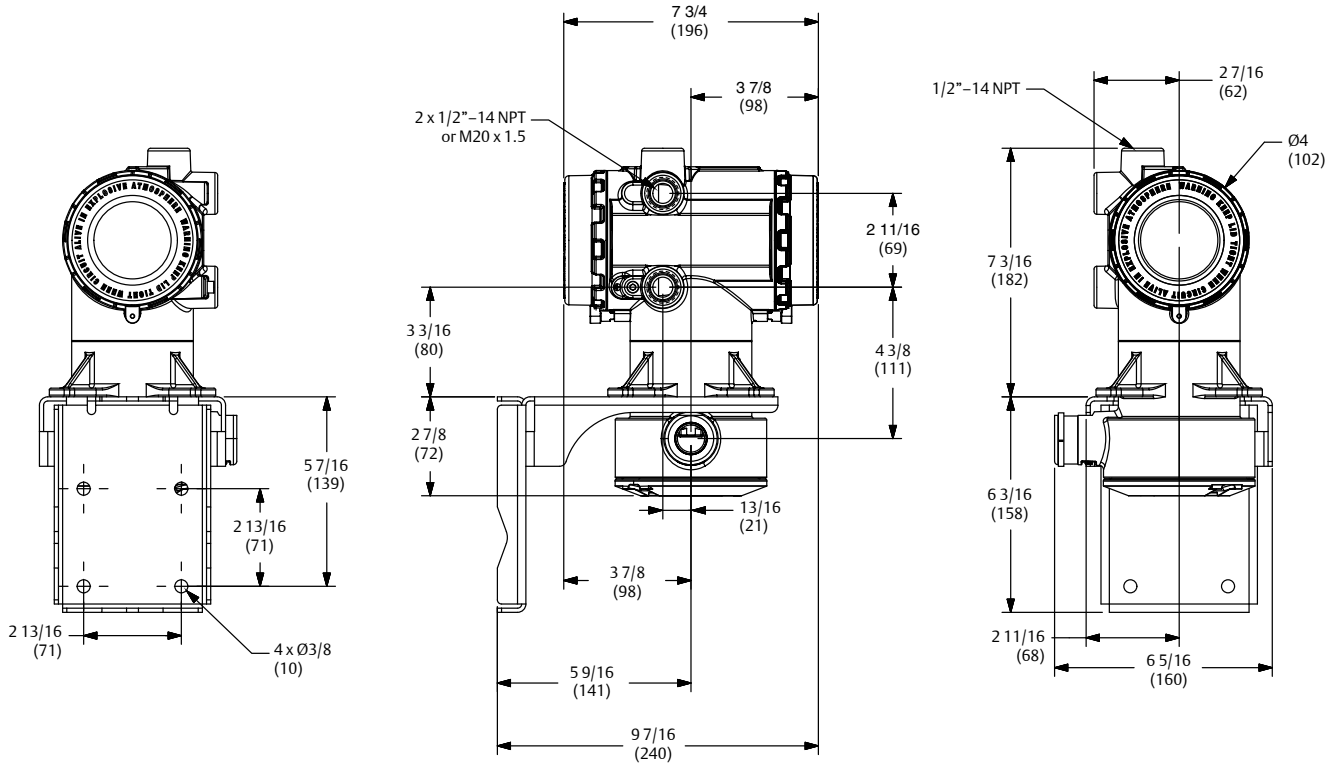

Remote core processor

Dimensions in inches (mm)

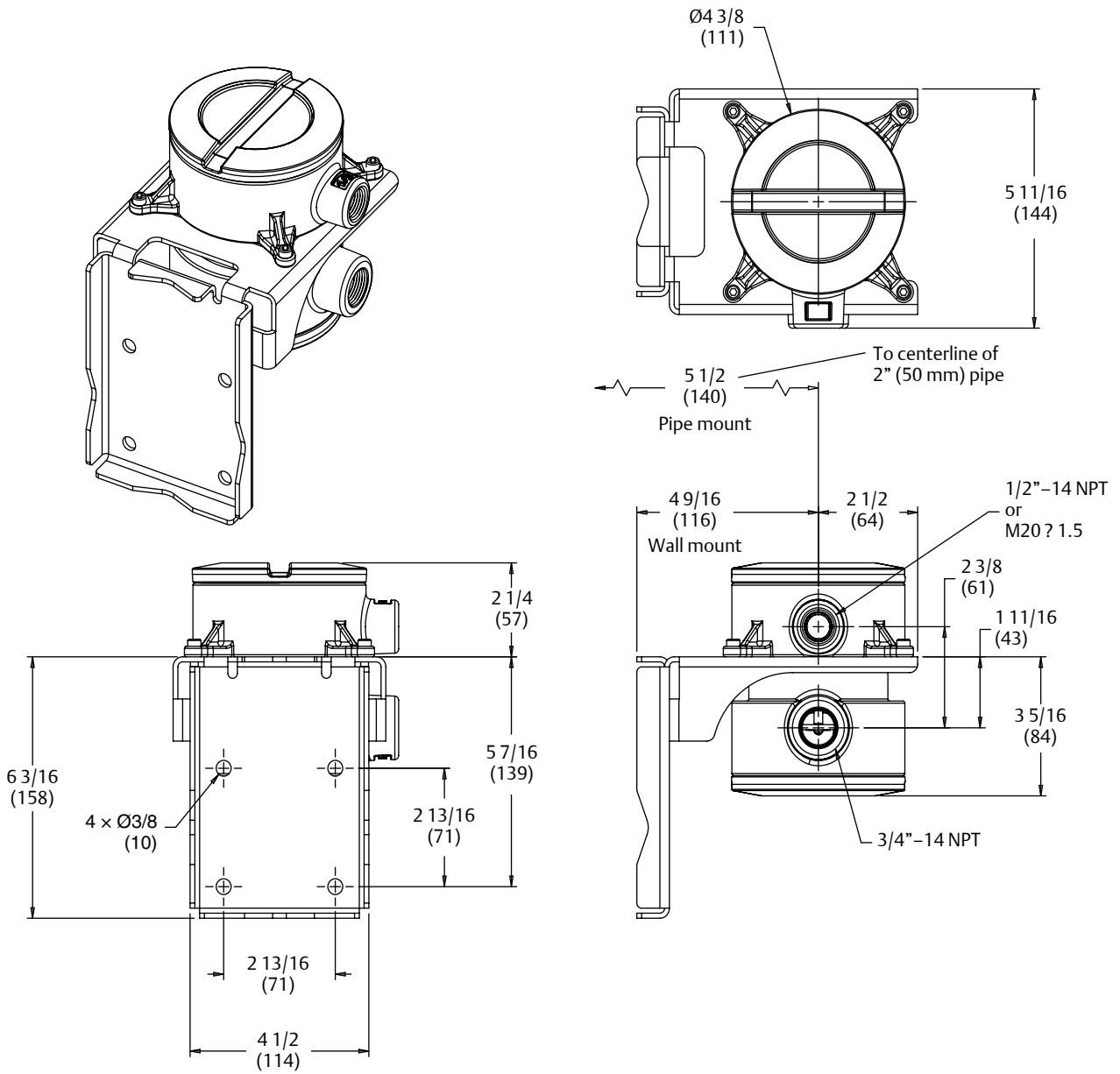

Model 2700 transmitter with Smart Wireless THUM™ Adapter

Output options 2 and 3 (all approval codes) and output option 4 (approval codes E and Z only)

The Model 2700 transmitter with the WirelessHART option provides an additional conduit opening at the top of the transmitter to install the Smart Wireless THUM Adapter. The THUM Adapter comes integrally mounted to the transmitter for output options 2 and 3 (all approval codes) and output option 4 (approval codes E and Z).

Dimensions in *inches*
(*mm*)

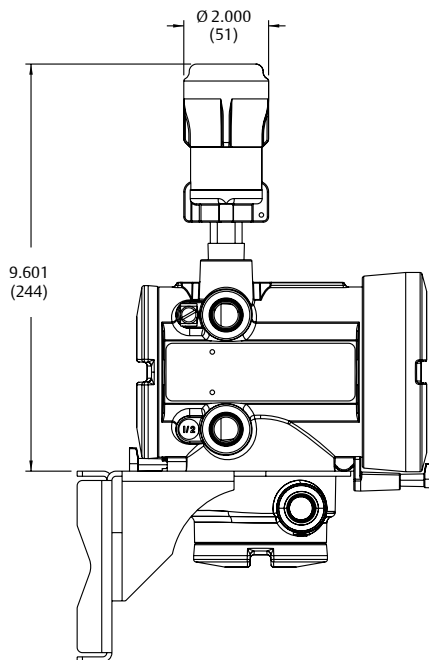
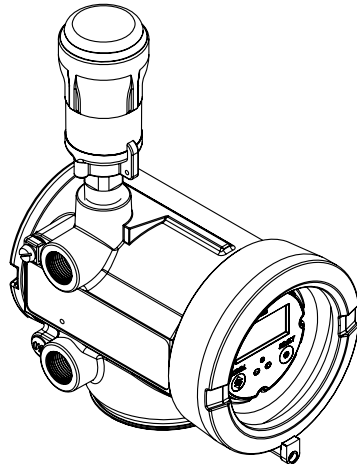

Remote-mount transmitter with integral-mount THUM Adapter

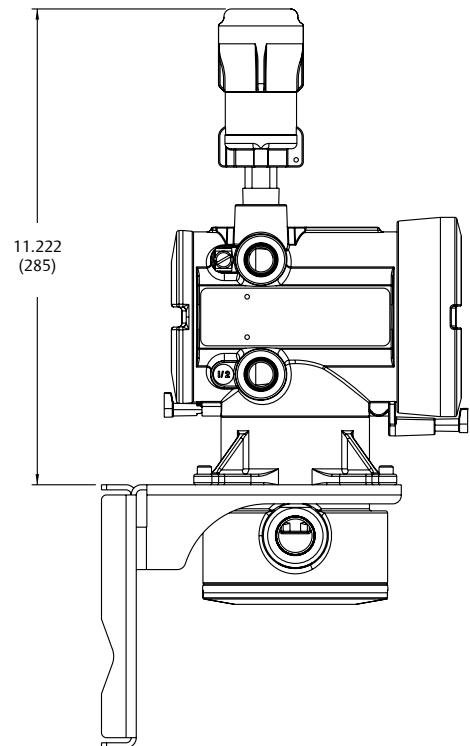

Remote-mount transmitter/core processor assembly with integral-mount THUM Adapter

Model 2700 transmitter with Smart Wireless THUM™ Adapter Output option 4 (approval code A)

The Model 2700 transmitter with WirelessHART output option 4 (approval code A) requires using poured conduit seals or a stopping box between the transmitter and Smart Wireless THUM Adapter. The THUM Adapter is not pre-installed for approval code A.

Dimensions in inches (mm)

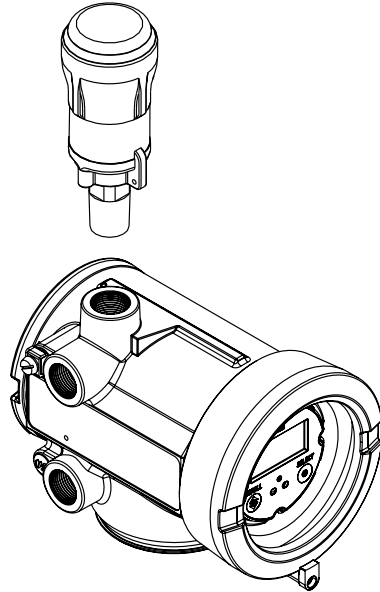

Smart Wireless THUM Adapter

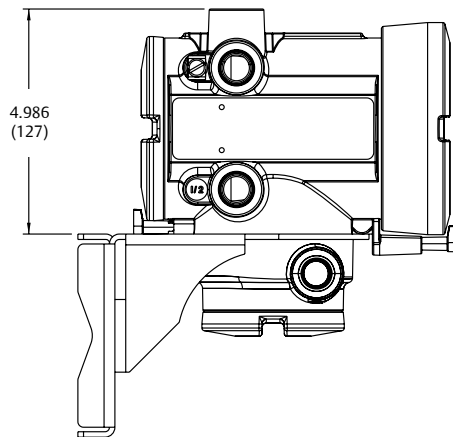
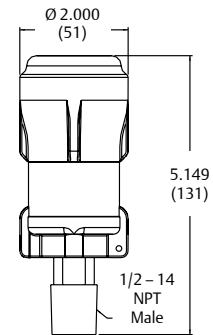

Remote-mount transmitter with additional conduit opening for installation of the THUM Adapter

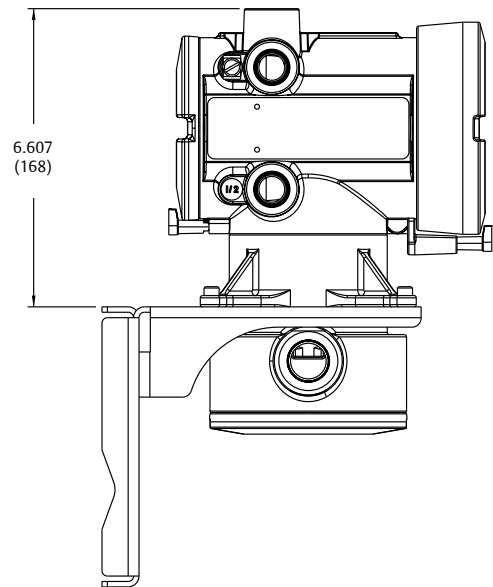

Remote-mount transmitter/core processor assembly with additional conduit opening for installation of the THUM Adapter

Model 1500/2500

Dimensions in inches
(mm)

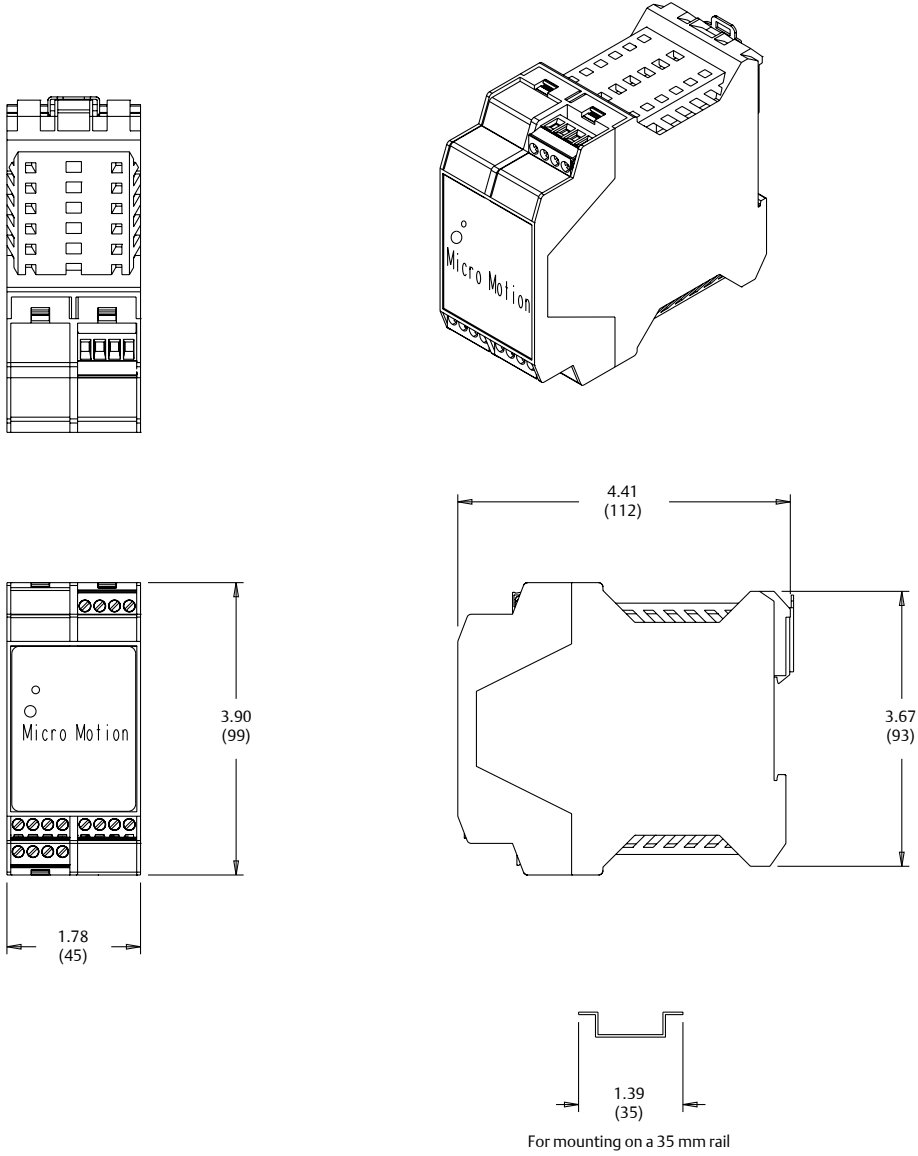

Ordering Information

Product Code Structure for Model 1700/2700

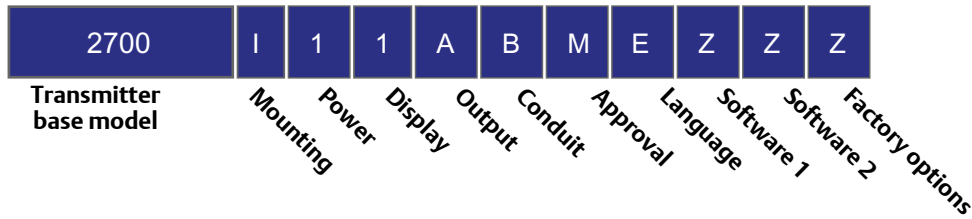

Model 1700

Base model

Model	Product description
1700	Micro Motion Coriolis MVD Model 1700 single variable flow transmitter

Mounting

Code	Mounting options for Model 1700
R	4-wire remote mount transmitter
I	Integral mount transmitter
B	4-wire remote mount transmitter with 9-wire remote core processor; includes 10 ft. (3 m) each of 4-wire shielded PVC cable and 9-wire shielded FEP cable; not available with conduit connection code C or D
C	9-wire remote transmitter; requires sensor with junction box; includes 10 ft. (3 m) 9-wire shielded FEP cable
M	4-wire remote mount transmitter with stainless steel housing; includes 10 ft. (3m) 4-wire shielded PVC cable; not available with approval codes U, Z, P, K, T, S, or J
P	9-wire remote mount transmitter with stainless steel housing and integral core processor; includes 10 ft. (3m) CFEPS cable; not available with approval codes U, Z, P, K, T, S, or J

Power

Code	Power options for Model 1700
1	18 to 100 VDC or 85 to 265 VAC; self switching

Display

Code	Display options for Model 1700
1	Dual line display for process variables and totalizer reset, glass lens; not available with mounting code M or P
2	Backlit dual line display for process variables and totalizer reset, glass lens
3	No display; not available with approval code J, T, or S
5	Backlit dual line display for IIC ATEX, IECEx, and NEPSI rating; glass lens; only available with approval codes Z, F, P, K or I
8	Display optimized for Chinese-language support; China only; available with mounting code R, I, C, or B, output code A, conduit connection code B, C, D, E, F or G, and approval code M, Z, F, P, K or I
7	Backlit dual line display for process variables and totalizer reset, non-glass lens; only available with approval code M; not available with mounting code M or P

Output

Code	Output options for Model 1700
A	Analog outputs: one mA; one frequency; RS-485; not available with display code 8
D	Intrinsically safe analog outputs: one mA, one frequency; not available with approval code T, S, or J

Conduit connection

Code	Conduit connection options for Model 1700
B	1/2-inch NPT – no gland; not available with approval code T, S, or J
C	1/2-inch NPT with brass/nickel cable gland; not available with approval code T, S, or J, or mounting code B, M, or P
D	1/2-inch NPT with stainless steel cable gland; not available with approval code T, S, or J, or mounting code B
E	M20 – no gland; not available with approval code T or S
F	M20 with brass/nickel cable gland; not available with approval code T, S, or J, or mounting code M or P
G	M20 with stainless steel cable gland; not available with approval code T, S, or J
K	JIS B0202 1/2G – no gland; only available with approval code M; not available with mounting code M or P
L	Japan - brass nickel cable gland; only available with approval code M, T, or S; not available with mounting code M or P
M	Japan - stainless cable gland; only available with approval code M, T, or S; not available with mounting code M or P

Approval

Code	Approval options for Model 1700
M	Micro Motion Standard (no approval)
U	UL; only available with conduit connection code B or E
C	CSA (Canada only)
A	CSA C-US (US and Canada)
Z	ATEX – Equipment Category 2 (Zone 1 – Increased safety terminal compartment)
F	ATEX – Equipment Category 2 (Zone 1 – Flameproof terminal compartment)
P	NEPSI – Equipment Category 2 (Zone 1 – Flameproof terminal compartment); only available with language code M (Chinese)
K	NEPSI – Equipment Category 2 (Zone 1 – Increased safety terminal compartment); only available with language code M (Chinese)
I	IECEx Equipment Category 2 (Zone 1 – Flameproof terminal compartment)
T	TIIS - IIC sensor (not available for quotes outside of Japan)
S	TIIS - IIB sensor (not available for quotes outside of Japan)
J	Hardware ready for TIIS approval (EPM Japan only)
G	Country Specific Approval - Requires a selection from the Approvals section of the Add on Option

Language

Code	Language options for Model 1700
A	Danish CE requirements document; English installation and configuration manuals
D	Dutch CE requirements document; English installation and configuration manuals
E	English installation manual; English configuration manual
F	French installation manual; French configuration manual
G	German installation manual; German configuration manual
H	Finnish CE requirements document; English installation and configuration manuals
I	Italian installation manual; English configuration manual
J	Japanese installation manual; Japanese configuration manual
M	Chinese installation manual; Chinese configuration manual
N	Norwegian CE requirements document; English installation and configuration manuals
O	Polish installation manual; English configuration manual
P	Portuguese installation manual; English configuration manual
S	Spanish installation manual; Spanish configuration manual
W	Swedish CE requirements document; English installation and configuration manuals
C	Czech installation manual; English configuration manual
B	Hungarian CE requirements document; English installation and configuration manuals
K	Slovak CE requirements document; English installation and configuration manuals
T	Estonian CE requirements document; English installation and configuration manuals
U	Greek CE requirements document; English installation and configuration manuals
L	Latvian CE requirements document; English installation and configuration manuals
V	Lithuanian CE requirements document; English installation and configuration manuals
Y	Slovenian CE requirements document; English installation and configuration manuals

Software 1

Code	Software options 1 for Model 1700
Z	Flow variable (standard)

Software 2

Code	Software options 2 for Model 1700
Z	No software options 2
C	Smart Meter Verification; only available with sensor electronic interface code 2, 3, 4, or 5; not available with mounting code I, B, C, or P
S	Safety certification of 4–20 mA output per IEC 61508; only available with output code A or D
V	Safety certification of 4–20 mA output per IEC 61508 with Smart Meter Verification; with ELITE electronic interface code 2, 3, 4, or 5; only available with output code A or D; not available with approval code J, T, or S

Factory

Code	Factory options for Model 1700
Z	Standard product
X	ETO product

Add on Options

Code	Add on options for Model 1700
CL	Hardware for cover lockout
PK	2-inch pipe mount U-bolt kit for electronics
	Country specific approval (select one from the following if approval code G is selected)
R1	EAC Zone 2 - Hazardous Area Approval - Increased safety terminal compartment (Exe)
R2	EAC Zone 1 - Hazardous Area Approval - Flameproof terminal compartment N/C
B1	INMETRO Zone 1 - Hazardous Area Approval - Increased safety terminal compartment N/C
B2	INMETRO Zone 1 - Hazardous Area Approval - Flameproof terminal compartment

Model 2700

Base model

Model	Product description
2700	Micro Motion Coriolis MVD Model 2700 multivariable flow and density transmitter

Mounting

Code	Mounting options for Model 2700
R	4-wire remote mount transmitter
I	Integral mount transmitter
B	4-wire remote mount transmitter with 9-wire remote core processor; includes 10 ft. (3 m) each of 4-wire shielded PVC cable and 9-wire shielded FEP cable; not available with conduit connection code C or D
C	9-wire remote transmitter; requires sensor with junction box; includes 10 ft. (3 m) 9-wire shielded FEP cable
M	4-wire remote mount transmitter with stainless steel housing; includes 10 ft. (3 m) 4-wire shielded PVC cable; not available with approval codes U, Z, P, K, T, S, or J; not available with output code 2 or 3
P	9-wire remote mount transmitter with stainless steel housing and integral core processor; includes 10 ft. (3m) CFEPS cable; not available with approval codes U, Z, P, K, T, S, or J; not available with output code 2 or 3
H	4-wire remote mount transmitter for connecting to CDM/FDM/FVM meters (power and communication); includes 10 ft. (3 m) 4-wire shielded PVC cable

Power

Code	Power options for Model 2700
1	18 to 100 VDC or 85 to 265 VAC; self switching

Display

Code	Display options for Model 2700
1	Dual line display for CSA, UL, and IIB + H2 ATEX, IECEx and NEPSI ratings; not available with mounting code M or P; not available with mounting code M, P, or H
2	Backlit dual line display for CSA, UL, and IIB + H2 ATEX, IECEx and NEPSI ratings
3	No display; not available with approval code J, T, or S
5	Backlit dual line display for IIC ATEX, IECEx, and NEPSI rating; glass lens; only available with approval codes Z, F, P, K, I, E, L, or 3
8	Display optimized for Chinese-language support; China only; only available with mounting code R, I, C, or B, output code A, conduit connection code B, C, D, E, F or G, and approval code M, Z, F, P, K or I
7	Backlit dual line display for process variables and totalizer reset, non-glass lens; only available with approval code M; not available with mounting code M, H, or P

Output

Code	Output options for Model 2700
E	FOUNDATION fieldbus intrinsically safe H1 with standard function blocks (4 x AI, 1 x AO, 1 x integrator, 1 x DI, 1 x DO); not available with approval code T, S, or J
	Not available with mounting code H:
A	Analog outputs: one mA; one frequency; RS-485; not available with display code 8
B	One mA; two configurable IO channels - default configuration of 2 mA, 1 FO
C	One mA; two configurable IO channels - custom configuration
D	Intrinsically safe analog outputs: two mA, one frequency; not available with approval code T, S, or J
G	PROFIBUS-PA; not available with approval codes U, 2, L and 3
N	FOUNDATION Fieldbus H1 with standard function blocks (4 x AI, 1 x AO, 1 x integrator, 1 x DI, 1 x DO); not available with approval code U, C, A, E, 2, L, 3
2	One mA; one frequency; RS485; Wireless HART ready; order 775 with 1/2" NPT mounting option; only available with approval codes M, 2, L, and 3
3	One mA; two configurable IO channels - custom configuration; Wireless HART ready; order 775 with 1/2" NPT mounting option; only available with approval codes M, 2, L, and 3
4	Intrinsically safe outputs; two mA; one frequency; Wireless HART ready; order 775 with 1/2" NPT mounting option; only available with approval codes E, Z or A when using stopping box or poured conduit seals between the transmitter and THUM

Conduit connection

Code	Conduit connection options for Model 2700	R	I	B	C	M	P	H
	Available with mounting codes:							
B	1/2-inch NPT – no gland; not available with approval code T, S, or J	•	•	•	•	•	•	•
	Only available with mounting code R, I, B, C, M, or P:							
C	1/2-inch NPT with brass/nickel cable gland; not available with approval code T, S, or J, or mounting code B, M, or P	•	•		•			
D	1/2-inch NPT with stainless steel cable gland; not available with approval code T, S, or J, or mounting code B							
E	M20 – no gland; not available with approval code T or S							
F	M20 with brass/nickel cable gland; not available with approval code T, S, or J, or mounting code M or P							
G	M20 with stainless steel cable gland; not available with approval code T, S, or J							
K	JIS B0202 1/2G – no gland; only available with approval code M; not available with mounting code M or P							
L	Japan - brass nickel cable gland; only available with approval code M, T, or S; not available with mounting code M or P							
M	Japan - stainless cable gland; only available with approval code M, T, or S; not available with mounting code M or P							

Approval

Code	Approval options for Model 2700
M	Micro Motion Standard (no approval)
U	UL; only available with conduit connection code B or E; not available with mounting code H
C	CSA (Canada only); not available with mounting code H
A	CSA C-US (US and Canada)
Z	ATEX – Equipment Category 2 (Zone 1 – Increased safety terminal compartment); not available with mounting code H
F	ATEX – Equipment Category 2 (Zone 1 – Flameproof terminal compartment)
P	NEPSI – Equipment Category 2 (Zone 1– Flameproof terminal compartment); only available with language code M (Chinese); not available with mounting code H
K	NEPSI – Equipment Category 2 (Zone 1 – Increased safety terminal compartment); only available with language code M (Chinese); not available with mounting code H
I	IECEX Equipment Category 2 (Zone 1 – Flameproof terminal compartment)
T	TIIS - IIC sensor (not available for quotes outside of Japan)
S	TIIS - IIB sensor (not available for quotes outside of Japan); not available with mounting code H
J	Hardware ready for TIIS approval (EPM Japan only); not available with mounting code H
E	IECEX (Zone 1 - Increased safety terminal compartment); only available with output code 4; not available with mounting code H
2	CSA Class 1 Div. 2 (US and Canada); sensor connections will be intrinsically Safe without additional barrier.
L	ATEX - Equipment Category 3 (Zone 2); sensor connections will be intrinsically Safe without additional barrier
3	IECEX (Zone 2); sensor connections will be intrinsically Safe without additional barrier
G	Country Specific Approval - Requires a selection from the Approvals section of the Add on Options

Language

Code	Language options for Model 2700
A	Danish CE requirements document; English installation and configuration manuals
D	Dutch CE requirements document; English installation and configuration manuals
E	English installation manual; English configuration manual
F	French installation manual; French configuration manual
G	German installation manual; German configuration manual
H	Finnish CE requirements document; English installation and configuration manuals
I	Italian installation manual; English configuration manual
J	Japanese installation manual; Japanese configuration manual
M	Chinese installation manual; Chinese configuration manual
N	Norwegian CE requirements document; English installation and configuration manuals
O	Polish installation manual; English configuration manual
P	Portuguese installation manual; English configuration manual

Language (continued)

Code	Language options for Model 2700 (continued)
S	Spanish installation manual; Spanish configuration manual
W	Swedish CE requirements document; English installation and configuration manuals
C	Czech installation manual; English configuration manual; not available with approval code J, T, or S
B	Hungarian CE requirements document; English installation and configuration manuals; not available with approval code J, T, or S
K	Slovak CE requirements document; English installation and configuration manuals; not available with approval code J, T, or S
T	Estonian CE requirements document; English installation and configuration manuals; not available with approval code J, T, or S
U	Greek CE requirements document; English installation and configuration manuals; not available with approval code J, T, or S
L	Latvian CE requirements document; English installation and configuration manuals; not available with approval code J, T, or S
V	Lithuanian CE requirements document; English installation and configuration manuals; not available with approval code J, T, or S
Y	Slovenian CE requirements document; English installation and configuration manuals; not available with approval code J, T, or S

Software 1

Code	Software options 1 for Model 2700
	Only available with mounting codes R, I, B, C, M, or P:
Z	Flow variable (standard)
G	Concentration measurement
A	Petroleum measurement
X	Flow variable (standard); requires factory code X
	Only available with mounting code H⁽¹⁾:
B	CDM density meter connection – IIC ATEX & IECEx rating; not available with display code 2
C	FDM density meter connection – IIC ATEX & IECEx rating; not available with display code 2
D	FVM density meter connection – IIC ATEX & IECEx rating; not available with display code 2
E	CDM density meter connection – CSA C1D1 & C1D2 and Zone 2 or 3 ATEX, IECEx
F	CDM density meter connection – CSA C1D1 & C1D2 and Zone 2 or 3 ATEX, IECEx
H	CDM density meter connection – CSA C1D1 & C1D2 and Zone 2 or 3 ATEX, IECEx

(1) All concentration measurement or petroleum measurement options are automatically programmed by the CDM / FDM or FVM and are defined in the CDM / FDM / FVM part number structure.

Software 2

Code	Software options 2 for Model 2700
	Available with all mounting codes:
Z	No software options 2
W	Weights & measures custody transfer; only available with output code A, B, C, 2 or 3; not available with software options 1 code C or D
X	ETO software option 2; requires factory code X
	Only available with mounting codes R, I, B, C, M or P:
A	Regulatory Control Suite: Standard function blocks plus 1 PID block; only available with output code E or N
S	Safety certification of 4–20 mA output per IEC 61508; only available with output code A, B, C, or D
V	Safety certification of 4–20 mA output per IEC 61508 with Smart Meter Verification; only available with output code A, B, C, or D and ELITE sensor electronic interface code 2, 3, 4, or 5; not available with approval code J, T, or S
	Only available with mounting codes R or M:
C	Smart Meter Verification; only available with sensor electronic interface code 2, 3, 4, or 5
D	Weights & measures custody transfer and Smart Meter Verification; only available with output code A, B, C, 2 or 3 and ELITE sensor electronic interface code 2, 3, 4, or 5
F	Regulatory Control Suite: Standard function blocks plus 1 PID block and Smart Meter Verification; only available with output code E or N and ELITE sensor electronic interface code 2, 3, 4, or 5

Factory

Code	Factory options for Model 2700
Z	Standard product
X	ETO product

Add on Options

Code	Add on options for Model 2700
	Only available for output code 2, 3, or 4:
PI	Model 775 integrally mounted at the factory, wiring completed in the field; not available with output code 4 and approval code A. CSA requires installation with a poured conduit seal or stopping box between the transmitter and the 775 Thum adapter.
NI	Model 775 not installed, installation and wiring completed in the field
	Only available for mounting code R, B, or C:
PK	2-inch pipe mount U-bolt kit for electronics; not available with output code 4 and approval code A. CSA requires installation with a poured conduit seal or stopping box between the transmitter and the 775 Thum
	Country specific approval (select one from the following if approval code G is selected):
R1	EAC Zone 2 - Hazardous Area Approval - Increased safety terminal compartment (Exe)
R2	EAC Zone 1 - Hazardous Area Approval - Flameproof terminal compartment N/C
R3 ⁽¹⁾	EAC Zone 2 - Hazardous Area Approval - Energy limited device (ExnA)
B1	INMETRO Zone 1 - Hazardous Area Approval - Increased safety terminal compartment N/C
B2	INMETRO Zone 1 - Hazardous Area Approval - Flameproof terminal compartment
B3 ⁽¹⁾	INMETRO Zone 2

(1) Sensor connections will be intrinsically safe without additional barrier

Product Code Structure for Model 1500/2500

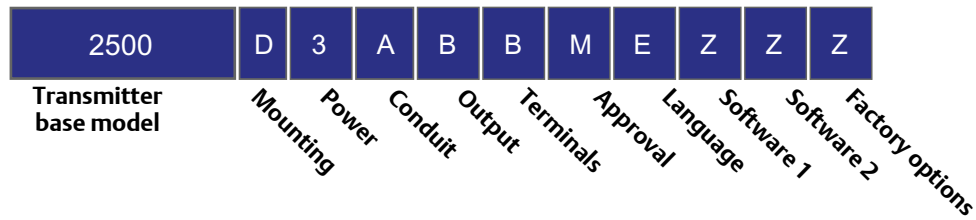

Model 1500

Base model

Model	Product description
1500	Micro Motion Coriolis MVD Model 1500 single variable DIN rail mount flow transmitter

Mounting

Code	Mounting options for Model 1500
D	4-wire remote 35 mm DIN rail transmitter
B	4-wire remote 35 mm DIN rail transmitter with 9-wire remote core processor; includes 10 ft. (3 m) 9-wire shielded FEP cable

Power

Code	Power options for Model 1500
3	19.2 to 28.8 VDC

Conduit connection

Code	Conduit connection options for Model 1500
With mounting code D:	
A	None
With mounting code B:	
B	1/2-inch NPT remote core processor – no gland
E	M20 remote core processor – no gland
F	Remote core processor – brass/nickel cable gland; not available with approval code S, T, or J
G	Remote core processor – stainless steel cable gland; not available with approval code S, T, or J
K	JIS B0202 1/2G – no gland; only available with approval code M, T, or S
L	Japan - brass nickel cable gland; only available with approval code M, T, or S
M	Japan - stainless cable gland; only available with approval code M, T, or S

Output

Code	Output options for Model 1500
A	One mA, one frequency, RS-485; not available with software 1 code B
C	One mA, two DO, RS-485; only available with software 1 code B

Terminal

Code	Terminal options for Model 1500
B	Screw terminals

Approval

Code	Approval options for Model 1500
M	Micro Motion Standard (no approval)
C	CSA (Canada only)
A	CSA C-US (US and Canada)
B	ATEX - Safe area with IS sensor outputs
P	NEPSI – Equipment Category 2 (Zone 1– Flameproof terminal compartment); only available with language code M (Chinese)
T	TIIS - IIC sensor (not available for quotes outside of Japan)
S	TIIS - IIB sensor (not available for quotes outside of Japan)
J	Hardware ready for TIIS approval (EPM Japan only)
G	Country Specific Approval - Requires a selection from the Approvals section of the Add on Options

Language

Code	Language options for Model 1500
A	Danish CE requirements document; English installation and configuration manuals
D	Dutch CE requirements document; English installation and configuration manuals
E	English installation manual; English configuration manual
F	French installation manual; French configuration manual
G	German installation manual; German configuration manual
H	Finnish CE requirements document; English installation and configuration manuals
I	Italian installation manual; English configuration manual
J	Japanese installation manual; Japanese configuration manual
M	Chinese installation manual; Chinese configuration manual
N	Norwegian CE requirements document; English installation and configuration manuals
O	Polish installation manual; English configuration manual
P	Portuguese installation manual; English configuration manual
S	Spanish installation manual; Spanish configuration manual
W	Swedish CE requirements document; English installation and configuration manuals
C	Czech installation manual; English configuration manual; not available with approval code J, T, or S
B	Hungarian CE requirements document; English installation and configuration manuals; not available with approval code J, T, or S
K	Slovak CE requirements document; English installation and configuration manuals; not available with approval code J, T, or S
T	Estonian CE requirements document; English installation and configuration manuals; not available with approval code J, T, or S
U	Greek CE requirements document; English installation and configuration manuals; not available with approval code J, T, or S
L	Latvian CE requirements document; English installation and configuration manuals; not available with approval code J, T, or S
V	Lithuanian CE requirements document; English installation and configuration manuals; not available with approval code J, T, or S
Y	Slovenian CE requirements document; English installation and configuration manuals; not available with approval code J, T, or S

Software 1

Code	Software options 1 for Model 1500
Z	Flow variable (standard)
B	Filling and dosing application; only available with output code A
X	ETO software option 1; requires factory code X

Software 2

Code	Software options 2 for Model 1500
Z	No software options 2
C	Smart Meter Verification; only available with ELITE electronic interface code 2 and 4; not available with mounting code B
X	ETO software option 2; requires factory code X

Factory

Code	Factory options for Model 1500
Z	Standard product
X	ETO product

Add on Options

Code	Add on options for Model 2700
PK	2-inch pipe mount U-bolt kit for electronics; not available with output code 4 and approval code A. CSA requires installation with a poured conduit seal or stopping box between the transmitter and the 775 Thum
	Country specific approval (select one from the following if approval code G is selected):
R4	EAC Safe Area Only with IS Sensor Outputs - Hazardous Area Approval
B4	INMETRO Safe Area Only with IS Sensor Outputs - Hazardous Area Approval

Model 2500

Base model

Model	Product description
2500	Micro Motion Coriolis MVD 2500 multivariable DIN rail mount flow transmitter

Mounting

Code	Mounting options for Model 2500
D	4-wire remote 35 mm DIN rail transmitter
B	4-wire remote 35 mm DIN rail transmitter with 9-wire remote core processor; includes 10 ft. (3 m) 9-wire shielded FEP cable

Power

Code	Power options for Model 1500
3	19.2 to 28.8 VDC

Conduit connection

Code	Conduit connection options for Model 2500
With mounting code D:	
A	None
With mounting code B:	
B	1/2-inch NPT remote core processor – no gland
E	M20 remote core processor – no gland
F	Remote core processor – brass/nickel cable gland; not available with approval code S, T, or J
G	Remote core processor – stainless steel cable gland; not available with approval code S, T, or J
K	JIS B0202 1/2G – no gland; only available with approval code M, T, or S
L	Japan - brass nickel cable gland; only available with approval code M, T, or S
M	Japan - stainless cable gland; only available with approval code M, T, or S

Output

Code	Output options for Model 2500
B	One mA, two configurable I/O channels, RS-485 – default configuration of two mA, one FO
C	One mA, two configurable I/O channels, RS-485 – custom configuration

Terminal

Code	Terminal options for Model 2500
B	Screw terminals

Approval

Code	Approval options for Model 2500
M	Micro Motion Standard (no approval)
C	CSA (Canada only)
A	CSA C-US (US and Canada)
B	ATEX - Safe area with IS sensor outputs
P	NEPSI – Safe area; only available with language code M (Chinese)
T	TIIS - IIC sensor (not available for quotes outside of Japan)
S	TIIS - IIB sensor (not available for quotes outside of Japan)
J	Hardware ready for TIIS approval (EPM Japan only)
G	Country Specific Approval - Requires a selection from the Approvals section of the Add on Options

Language

Code	Language options for Model 2500
A	Danish CE requirements document; English installation and configuration manuals
D	Dutch CE requirements document; English installation and configuration manuals
E	English installation manual; English configuration manual
F	French installation manual; French configuration manual
G	German installation manual; German configuration manual
H	Finnish CE requirements document; English installation and configuration manuals
I	Italian installation manual; English configuration manual
J	Japanese installation manual; Japanese configuration manual
M	Chinese installation manual; Chinese configuration manual
N	Norwegian CE requirements document; English installation and configuration manuals
O	Polish installation manual; English configuration manual
P	Portuguese installation manual; English configuration manual
S	Spanish installation manual; Spanish configuration manual
W	Swedish CE requirements document; English installation and configuration manuals
C	Czech installation manual; English configuration manual; not available with approval code J, T, or S
B	Hungarian CE requirements document; English installation and configuration manuals; not available with approval code J, T, or S
K	Slovak CE requirements document; English installation and configuration manuals; not available with approval code J, T, or S
T	Estonian CE requirements document; English installation and configuration manuals; not available with approval code J, T, or S
U	Greek CE requirements document; English installation and configuration manuals; not available with approval code J, T, or S
L	Latvian CE requirements document; English installation and configuration manuals; not available with approval code J, T, or S
V	Lithuanian CE requirements document; English installation and configuration manuals; not available with approval code J, T, or S
Y	Slovenian CE requirements document; English installation and configuration manuals; not available with approval code J, T, or S

Software 1

Code	Software options 1 for Model 2500
Z	Flow and density variables (standard)
G	Concentration measurement; not available with approval code T or J
A	Petroleum measurement
X	ETO software option 1; requires factory code X

Software 2

Code	Software options 2 for Model 2500
Z	No software options 2
C	Smart Meter Verification; only available with ELITE sensor electronic interface code 2 and 4; not available with mounting code B
W	Weights and measures custody transfer; requires user-provided external sealing for approval
D	Weights and measures custody transfer and Smart Meter Verification; requires user-provided external sealing; only available with ELITE electronic interface codes 2 or 4; not available with mounting code B or approval code T or J
X	ETO software option 2; requires factory code X

Factory

Code	Factory options for Model 2500
Z	Standard product
X	ETO product

Add on Options

Code	Add on options for Model 2700
PK	2-inch pipe mount U-bolt kit for electronics; not available with output code 4 and approval code A. CSA requires installation with a poured conduit seal or stopping box between the transmitter and the 775 Thum
	Country specific approval (select one from the following if approval code G is selected):
R4	EAC Safe Area Only with IS Sensor Outputs - Hazardous Area Approval
B4	INMETRO Safe Area Only with IS Sensor Outputs - Hazardous Area Approval

Emerson Process Management Americas

7070 Winchester Circle
Boulder, Colorado USA 80301
www.MicroMotion.com
www.Rosemount.com
T: +1 800 522 6277
T: +1 (303) 527 5200
F: +1 (303) 530 8459

Mexico T: 52 55 5809 5300
Argentina T: 54 11 4837 7000
Brazil T: 55 15 3413 8000
Venezuela T: 58 26 1300 8100
Chile T: 56 2 2928 4800

Emerson Process Management Europe/Middle East

Central & Eastern Europe T: +41 41 7686 111
Dubai T: +971 4 811 8100
Abu Dhabi T: +971 2 697 2000
France T: 0800 917 901
Germany T: 0800 182 5347
Italy T: 8008 77334
The Netherlands T: +31 (0) 70 413 6666
Belgium T: +32 2 716 77 11
Spain T: +34 913 586 000
U.K. T: 0870 240 1978
Russia/CIS T: +7 495 981 9811

Emerson Process Management Asia Pacific

Australia T: (61) 3 9721 0200
China T: (86) 21 2892 9000
India T: (91) 22 6662 0566
Japan T: (81) 3 5769 6803
South Korea T: (82) 2 3438 4600
Singapore T: (65) 6 777 8211

© 2015 Micro Motion, Inc. All rights reserved.

The Emerson logo is a trademark and service mark of Emerson Electric Co. Micro Motion, ELITE, ProLink, MVD and MVD Direct Connect marks are marks of one of the Emerson Process Management family of companies. All other marks are property of their respective owners.

Micro Motion supplies this publication for informational purposes only. While every effort has been made to ensure accuracy, this publication is not intended to make performance claims or process recommendations. Micro Motion does not warrant, guarantee, or assume any legal liability for the accuracy, completeness, timeliness, reliability, or usefulness of any information, product, or process described herein. We reserve the right to modify or improve the designs or specifications of our products at any time without notice. For actual product information and recommendations, please contact your local Micro Motion representative.

