

DESPIECE

DISASSEMBLY

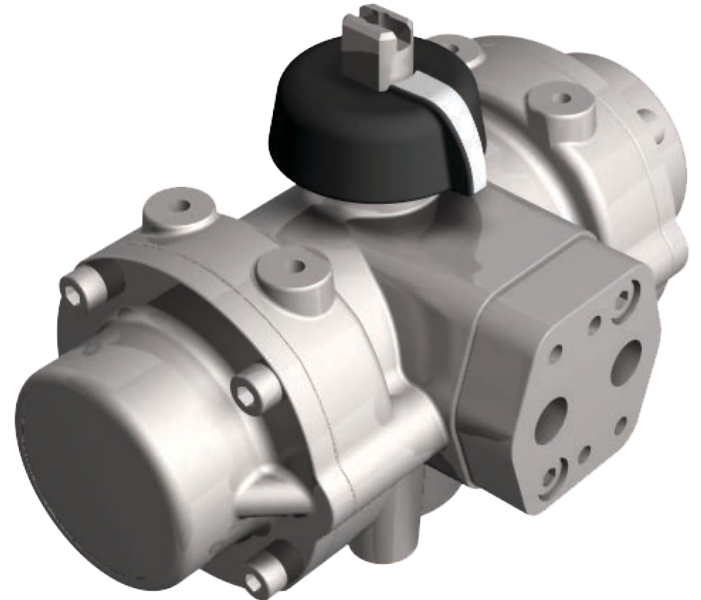

ACTUADOR NEUMÁTICO DE ACERO INOXIDABLE CF8M  
CF8M STAINLESS STEEL PNEUMATIC ACTUATOR



**PI00:** Doble Efecto / Double Acting

**PI00S:** Simple Efecto / Spring Return

Nº	Descripción Description	Cant. Quant.	Material Material
1	TORNILLO ALLEN TAPA CAP ALLEN SCREW	8	ACERO INOX. AISI-316 AISI-316 STAINLESS STEEL
2	TAPA CAP	2	ACERO INOXIDABLE CF8M CF8M STAINLESS STEEL
3	JUNTA TÓRICA TAPA CAP-O-RING	2	N.B.R. N.B.R.
4	ÉMBOLO PISTON	2	POLIARILAMIDA POLYARILAMIDE
5	CILINDRO CYLINDER	1	ACERO INOXIDABLE CF8M CF8M STAINLESS STEEL
6	ARANDELA WASHER	1	POLIAMIDA 6 POLYAMIDE 6
7	ANILLO DE SEGURIDAD SPRING CLIP	1	ACERO INOXIDABLE STAINLESS STEEL
8	INDICADOR VISUAL POSITION INDICATOR	1	POLIAMIDA POLYAMIDE
9	GUÍA ÉMBOLO PISTON GUIDE	2	POLIACETAL POLYACETAL
10	ANILLO GUÍA GUIDE RING	2	POLIACETAL POLYACETAL
11	JUNTA TÓRICA ÉMBOLO PISTON O-RING	2	N.B.R. N.B.R.
12	JUNTA TÓRICA EJE SHAFT O-RING	2	N.B.R. N.B.R.
13	JUNTA TÓRICA EJE SHAFT O-RING	2	N.B.R. N.B.R.
14	JUEGO MUELLES PRECARGADOS PRELOADED SPRINGS SET	1	DIN-17223-C (2) (4) DIN-17223-C (2) (4)
16	EJE SHAFT	1	ACERO INOX AISI-316 AISI-316 STAINLESS STEEL
18	JUNTA TÓRICA PLACA PLATE O-RING	2	N.B.R. N.B.R.
19	JUNTA TÓRICA TAPA CAP O-RING	2	N.B.R. N.B.R.
20	PLACA CONEXIÓN NEUMÁTICA PNEUMATIC CONNECTION PLATE	1	ACERO INOXIDABLE CF8M CF8M STAINLESS STEEL
21	TORNILLO ALLEN PLACA PLATE ALLEN SCREW	2	ACERO INOXIDABLE AISI-316 AISI-316 STAINLESS STEEL

(2) RECUBRIMIENTO POR CATAFORESIS.  
COVERED BY CATAPHORESIS.

(4) CANTIDAD VARIABLE, CONSULTAR TABLAS PARES SIMPLE EFECTO.  
VARIABLE QUANTITY, PLEASE SEE THE SPRING RETURN TORQUE CHART.

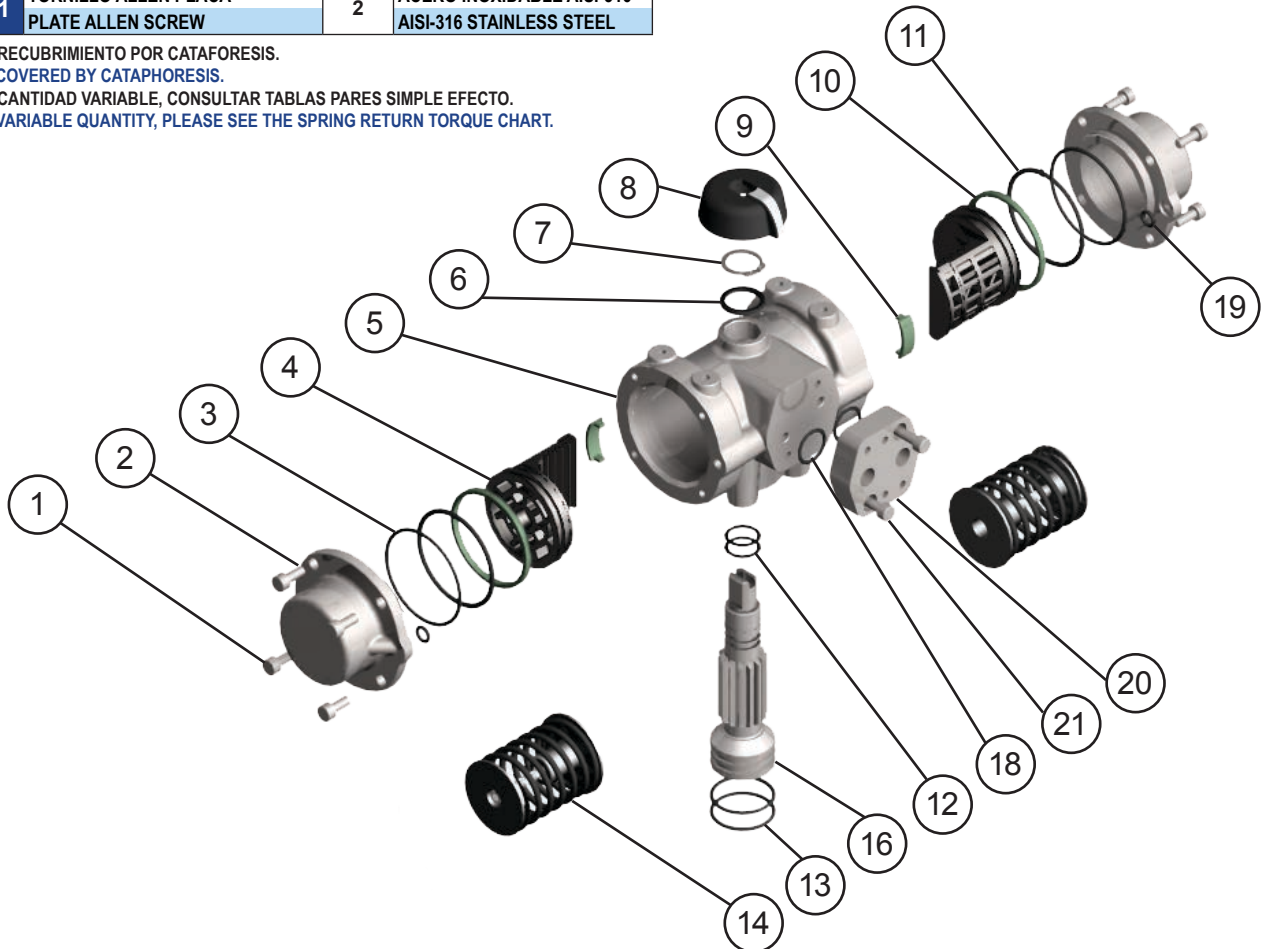

MODELOS MODELS	TIEMPO DE MANIOBRA EN SEG. CYCLE TIME IN SECS.		PESOS WEIGHTS		CAPACIDAD EN LITROS CAPACITY IN LITRES	
	PARA ABRIR TO OPEN	PARA CERRAR TO CLOSE	Kg.	Lb.	PARA ABRIR TO OPEN	PARA CERRAR TO CLOSE
PI00	0,15	0,15	2,2	4,85	0,15	0,1
PI00S	0,2	0,2	2,6	5,73	0,15	

Tiempo de maniobra sin par resistente a 6 bar.  
Cycle time w/o resistant torque at 6 bar.

Dimensiones en mm.  
Dimensions in mm.

Para calcular el consumo, multiplicar las cifras del cuadro por la presión real de trabajo.

To calculate the consumption, multiply the above figures by the real working pressure.

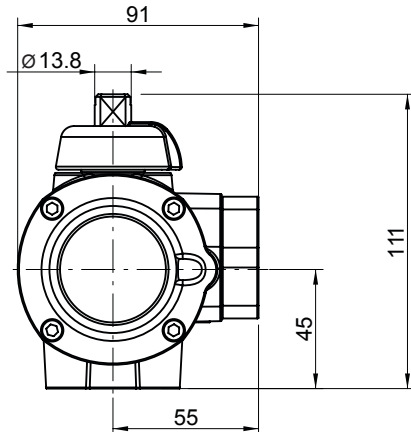
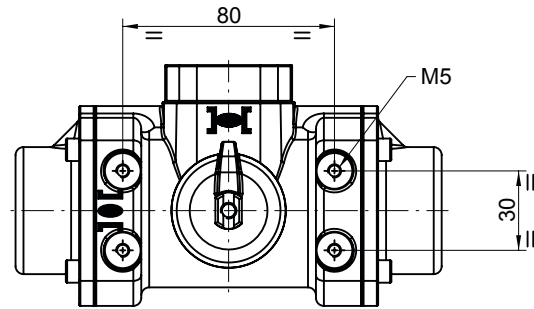
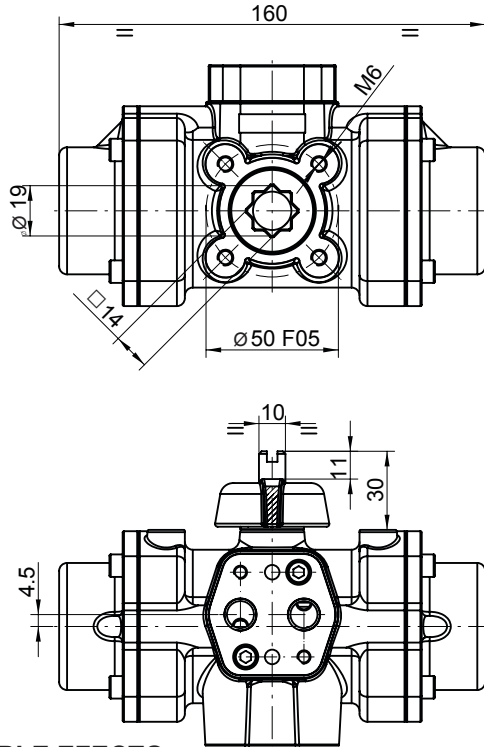

### PARES DOBLE EFECTO DOUBLE ACTING TORQUES

PI00	PRESION AIRE AIR PRESSURE								
	bar	3	4	4,5	5	5,5	6	7	8
p.s.i	43,5	58	65,3	72,5	79,8	87	101,5	116	
Nm	11,6	16,1	18,3	20,5	22,8	25	29,5	33,9	
Lb.in	102,7	142,5	162	181,4	201,8	221,3	262,1	300	

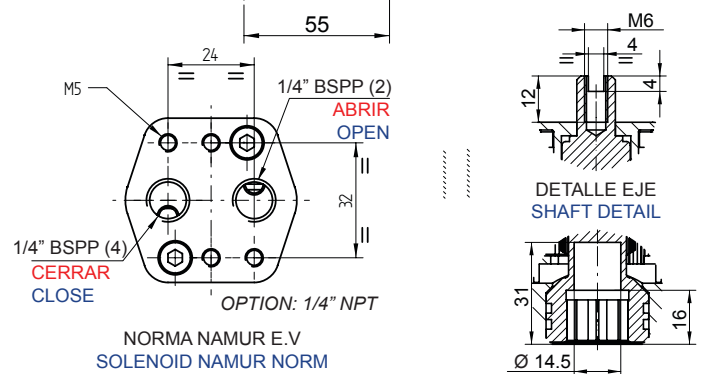

### PARES SIMPLE EFECTO SPRING RETURN TORQUES

PI00S	PAR MUELLES SPRING TORQUES		PAR A LA PRESIÓN INDICADA AIR TORQUE AT INDICATED PRESSURE																	
			3		4		4,5		5		5,5		6		7		8		bar	
	INICIAL INITIAL	FINAL END	43,5	58	65,3	72,5	79,8	87	101,5	116									p.s.i	
N																				
4*	15,9	11,3						7	2,4	9,2	4,6	11,5	6,9	13,7	9,1	18,1	13,5	22,6	18	Nm
	141	100,3						61,7	21	81,4	40,8	101,2	61,1	121,2	80,3	160,5	119,7	200,2	159,3	Lb.in
3	13,1	10,3			5,8	3	8	5,2	10,3	7,4	12,5	9,7	14,7	11,9	19,2	16,3	23,6	20,8		Nm
	116,1	90,8			51,4	26,2	71,2	45,9	91	65,7	110,6	85,8	130,4	105,1	169,9	144,6	209	183		Lb.in
2	10,5	7,4	4,2	1,1	8,7	5,6	10,9	7,8	13,1	10,1	15,4	12,3	17,6	14,5	22,1	19				Nm
	92,7	65,6	37,3	10	76,5	49,5	96,4	69,3	116,2	88,9	136,3	108,9	155,7	128,4	195,1	167,9				Lb.in
1	7	4,8	6,8	4,7	11,3	9,1	13,5	11,3	15,8	13,6	18	15,8	20,2	18						Nm
	61,6	42,2	60,5	41,2	100	80,3	119,8	100,4	139,5	120,2	159,3	139,8	178,9	159,3						Lb.in

N: Número de muelles por banda  
Number of springs per side

\* Número de muelles estándar  
\* Standard number of springs